

BRISTAN

Installation Instructions and User Guide

Opac Thermostatic Surface
Mounted Bar Shower Valves

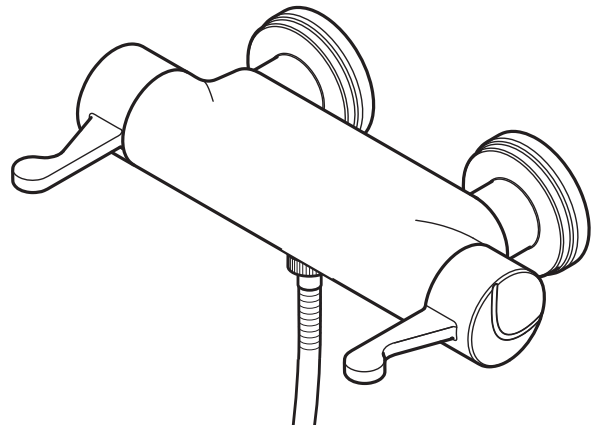
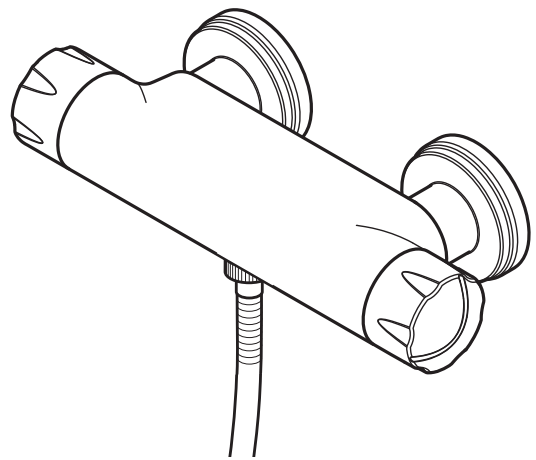

Models covered: OP SHXVO EH C &
OP SHXVO EL C

Please keep this booklet for future
reference.

Installer, when you have read these
instructions please ensure you leave them
with the user.



Contents

Thank you for choosing Bristan, the UK's leading showers and taps expert.

Your Bristan shower valve is a thermostatic mixer incorporating a wax capsule thermostat to ensure constant shower temperatures. These instructions are for your guidance to a safe and successful installation and should be left with the user. All products manufactured and supplied by Bristan are safe providing they are installed correctly and receive regular maintenance in accordance with these instructions.

Important Safety Information.....	3
General Information	4
Product Features.....	5
Specifications	6
Dimensions.....	7
Pack Contents	8-9
Installation Requirements	10-15
System Requirements	10-11
WRAS IRN's	12
TMV2	13
TMV3	14
Flow Regulators	15
Installation	16-18
First Fix	16-17
Second Fix.....	18
Operating the shower.....	19
Commissioning.....	20
In-Service Testing	21-22
Maintenance	23-25
Cartridge Maintenance	23
Adjusting the Temperature	24
Thermal Disinfection Flushing	25
Troubleshooting.....	26-27
Notes	28-29
Guarantee	30-31

Important Safety Information

- Please read these instructions thoroughly and retain for future use.
- All products manufactured and supplied by Bristan are safe provided they are installed, used correctly and receive regular maintenance in accordance with these instructions.
- **If you are in any doubt about your ability to install this shower valve safely you must employ the services of an experienced qualified plumber.**
- These fittings need to be installed in accordance with, and meet the requirements of the Water Supply (Water Fittings) Regulations 1999 and Scottish Byelaws 2004.
-  **Warning:** Do not operate the shower valve if you suspect it is frozen. Do not site the shower valve where it might be subjected to freezing conditions.
- Remove all packaging and check the contents for damage before starting installation.
- Before starting any installation please consider the following: before drilling into walls, check that there are no hidden electrical wires, cables or water supply pipes. This can be checked with the aid of an electronic detector.
- If power tools are used do not forget to:
 - Wear eye protection
 - Unplug equipment after use
- Fitting isolating valves to the inlet feeds is required for ease of maintenance.
-  **Warning:** Before installing the new shower valve it is essential that you thoroughly flush through the pipework in order to remove any remaining swarf, solder, etc. Failure to carry out this procedure could cause problems or damage to the workings of the shower valve.
- This shower valve **must** not be modified in any way as this will invalidate the guarantee.

General Information

Operating pressure range: Minimum 0.2 bar, Maximum 5.0 bar.

Maximum static pressure: 10.0 bar.

This product has been tested to the TMV2 scheme which complies with the BS EN 1287:1999 (LP) and BS 1111:1999 (HP) thermostatic mixing valve standards and the TMV3 scheme for use in Healthcare and Commercial situations and performs to the requirements of NHS Specification D08. It also satisfies the requirements of the water supply (water fittings) regulations 1999 and current bylaws.

BS 6700 recommends the temperature of stored water should never exceed 65°C. A stored water temperature of 60°C is considered sufficient to meet all normal requirements and will minimise the build up of lime scale in hard water areas.

If the fitting is installed at low pressure (tank fed), then the minimum distance from the highest installed position of the showerhead to the underside of the cold tank should be at least 2 metres to ensure adequate performance.

Note: Nominally equal (balanced) inlet supply pressures are recommended for optimum performance with mixer showers.

This shower valve should be installed in compliance with the Water Regulations.

If in doubt, contact a registered plumber or your Local Water Authority or the Secretary of The Institute of Plumbing, address as follows;-

The Institute of Plumbing,
64 Station Lane,
Hornchurch,
Essex, RM12 6NB
Tel:01708 472791

Recommended Usage			
Domestic	✓	Heavy Commercial	✓
Light Commercial	✓	Health Care	✓

Product features

1. Temperature Control

Adjustable temperature control.

Turn the control clockwise to increase the temperature.

Turn the control anti-clockwise to decrease the temperature.

2. Water Flow Control

Controls the amount or flow of water from the showerhead.

Turn the control clockwise to turn on and increase the flow.

Turn anti-clockwise to reduce the flow and turn off.

3. Thermal Disinfection Flushing

In order to control the build up of bacteria and to assist against legionella, this TMV has a built in cleansing feature that allows the mixed water passages to be flushed with hot water without the need to disassemble the shower valve or reset the mixed water temperature.

4. TMV2 Approved

This TMV has been tested to the TMV2 scheme which complies with the BS EN 1287:1999 (LP) and BS EN 1111:1999 (HP) thermostatic mixing valve standards.

5. TMV3 Approved

This TMV has been tested to the TMV3 scheme for use in Healthcare and Commercial situations and performs to the requirements of NHS Specification D08.

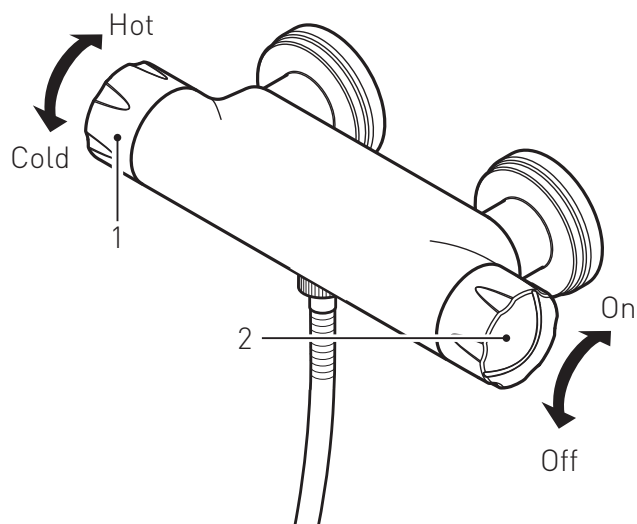

Specifications

Specifications

Inlet connections: 15mm compression with 150mm between centres.

Outlet connection: G1/2"

Operating pressure range: Min. 0.2 Bar - Max. 5.0 Bar - Maximum recommended imbalance between hot and cold supply should not exceed a ratio of 5:1.

Maximum Static Pressure: 10 Bar

Maximum outlet temp: Factory pre-set to 41°C

(can be re-set to suit site conditions). If the temperature is re-set to suit different site conditions the valve will work adequately however the TMV3 scheme will not apply.

Supply requirements:

Minimum cold water supply temperature: 5°C.

Maximum cold water supply temperature: 25°C.

Maximum hot water supply temperature: 80°C.

(a maximum hot water supply temperature of 60 - 65°C is recommended for ablutionary purposes)

Note: The inlet hot water temperature must be at least 10°C above the required blend temperature (eg. shower temperature 43°C: minimum hot supply 53°C).

Dimensions (mm's)

OP SHXVO EH C

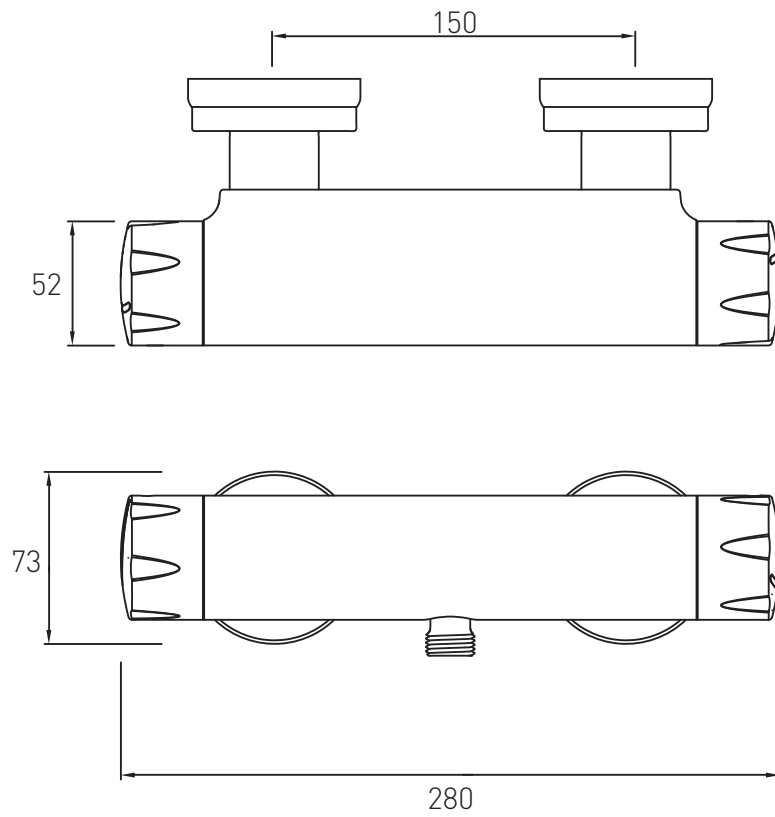

OP SHXVO EL C

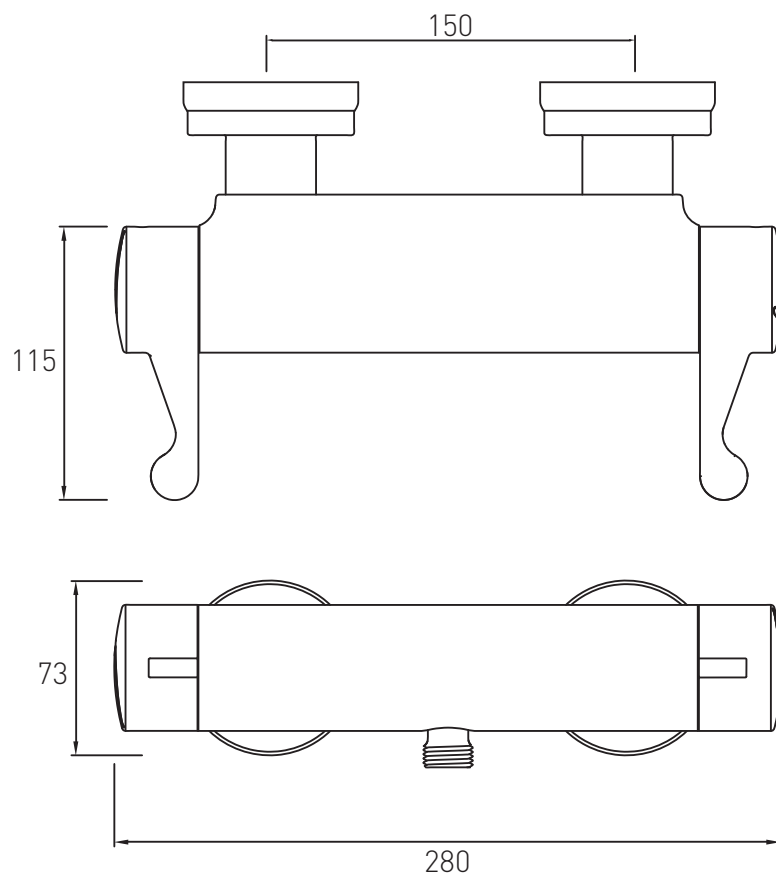

Pack Contents - OP SHXVO EH C

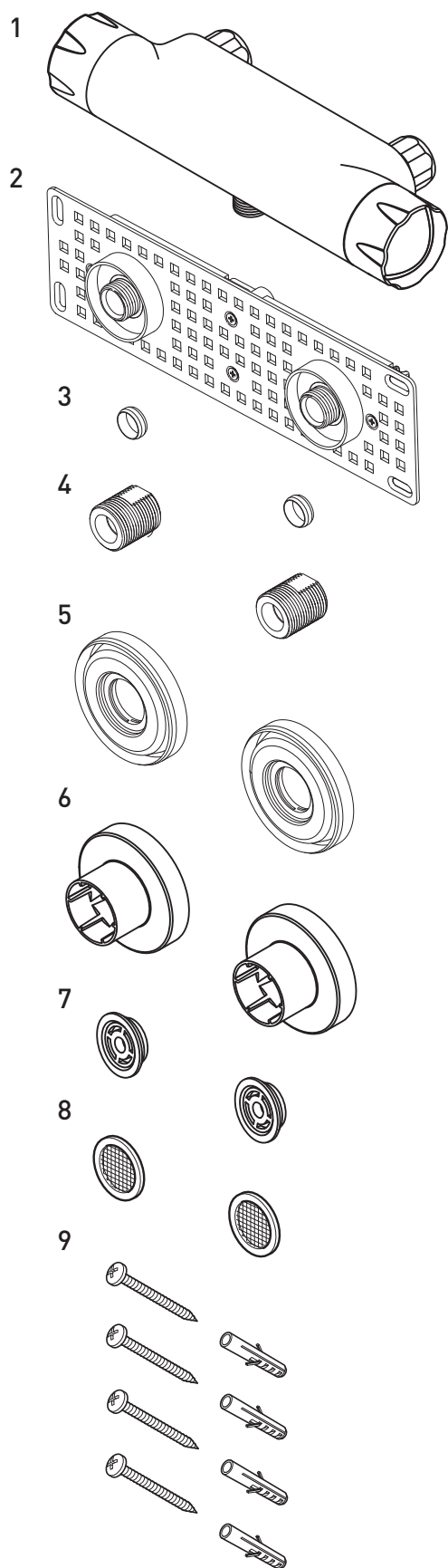

- 1 Shower valve x1
- 2 Wall mount fixing plate x1
- 3 Olives x2
- 4 Fixing bridges x2
- 5 Rear covers x2
- 6 Front covers x2
- 7 Flow regulators (Pre-fitted) x2
- 8 Filter washers x2
- 9 Wall plate fixings x4/4

Pack Contents - OP SHXVO EL C

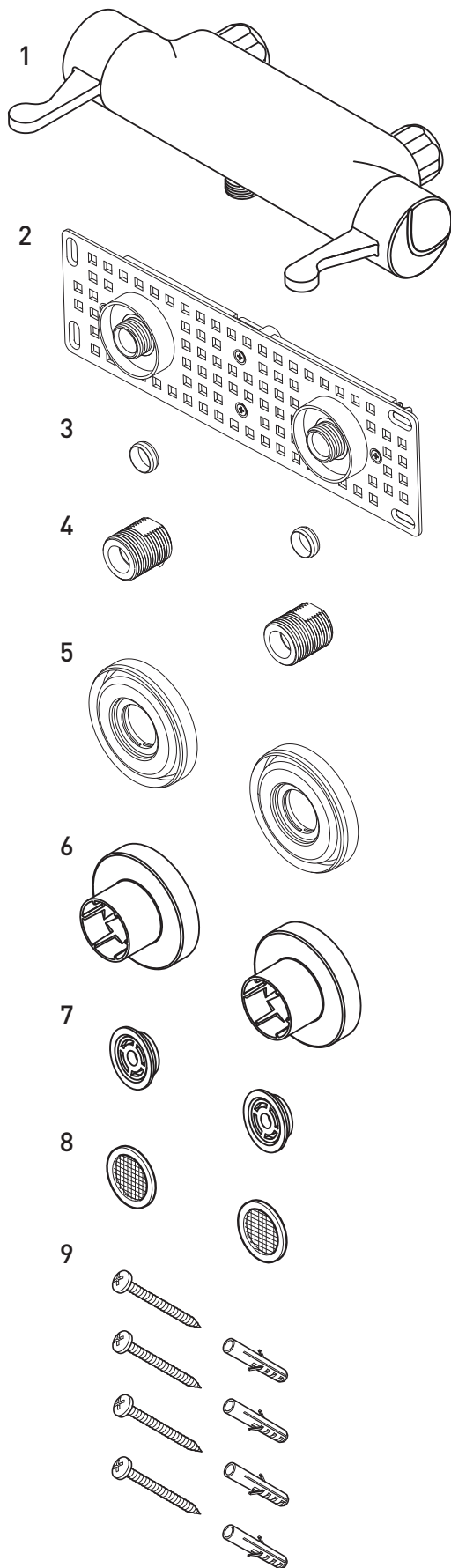

- 1 Shower valve x1
- 2 Wall mount fixing plate x1
- 3 Olives x2
- 4 Fixing bridges x2
- 5 Rear covers x2
- 6 Front covers x2
- 7 Flow regulators (Pre-fitted) x2
- 8 Filter washers x2
- 9 Wall plate fixings x4/4

Installation Requirements

This shower valve must be installed in compliance with current water regulations. If you have any doubts about the water regulation requirements contact your local water services provider or use the services of a professional plumber.

This shower valve is suitable for use with the following water supply systems:

- **Gravity Fed Hot and Cold**
(pressure balanced)
- **Gravity Fed Hot and Mains Cold**
(differential pressure - see Specification section on page 6)
- **Instantaneous water heater**
(combination boiler)
- **Unvented System**
- **Pumped System**

Gravity Fed Hot and Cold

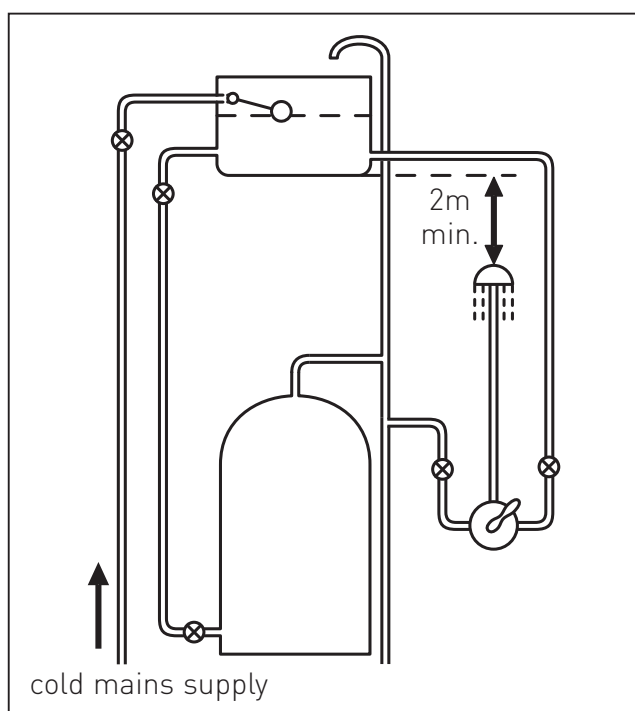

⚠ Important: If you install this shower valve with a gravity fed system, there must be a minimum head (vertical distance) from the underside of the cold water storage tank to the showerhead position of at least 2 metres .

Note: Pumped system (with Essex flange) If you install this shower valve to a pumped gravity fed system where the minimum head (vertical distance) from the underside of the cold water storage tank to the top of the hot water cylinder is less than 1 metre we recommend an Essex flange is used as shown.

Flushing Pipe-work

⚠ Important: Before connecting the shower valve (see 'Installation' on pages 16-18), supply pipe-work **must** be flushed to clear debris before connecting the shower valve. Debris will reduce the performance and life of the shower.

Gravity Fed Hot and Mains Cold

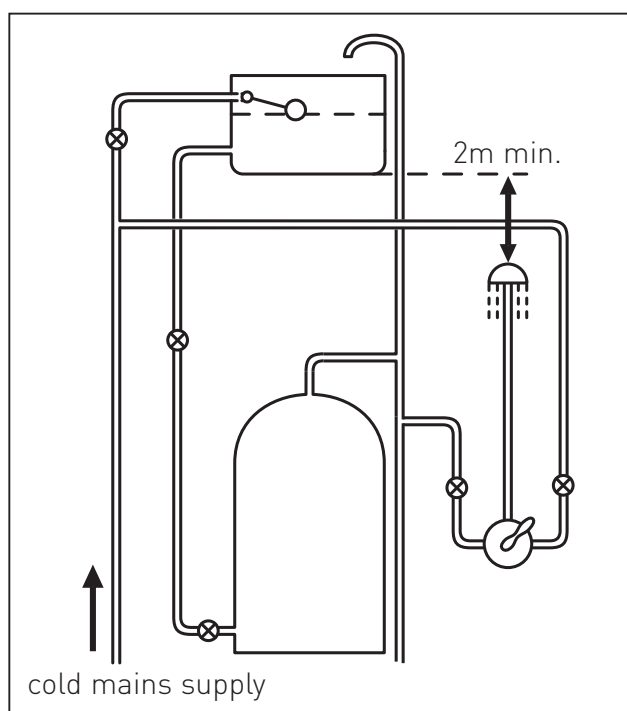

Installation Requirements

Instantaneous Water Heater

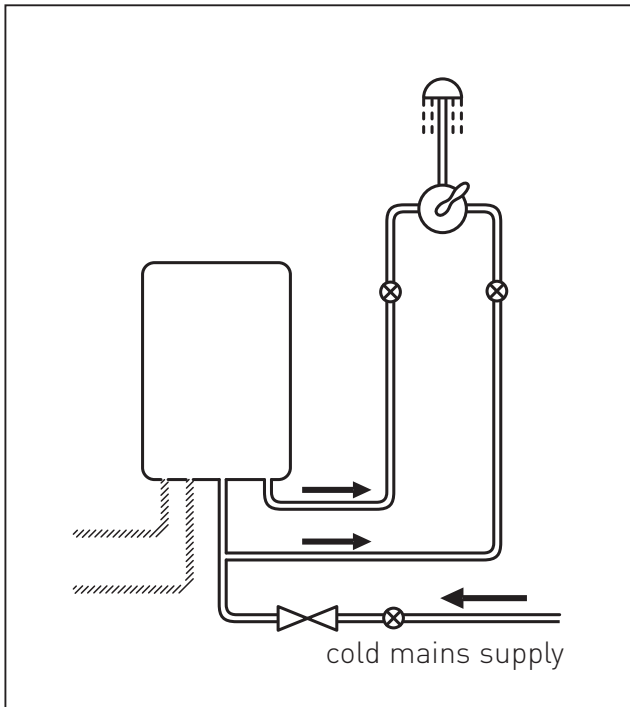

Unvented System

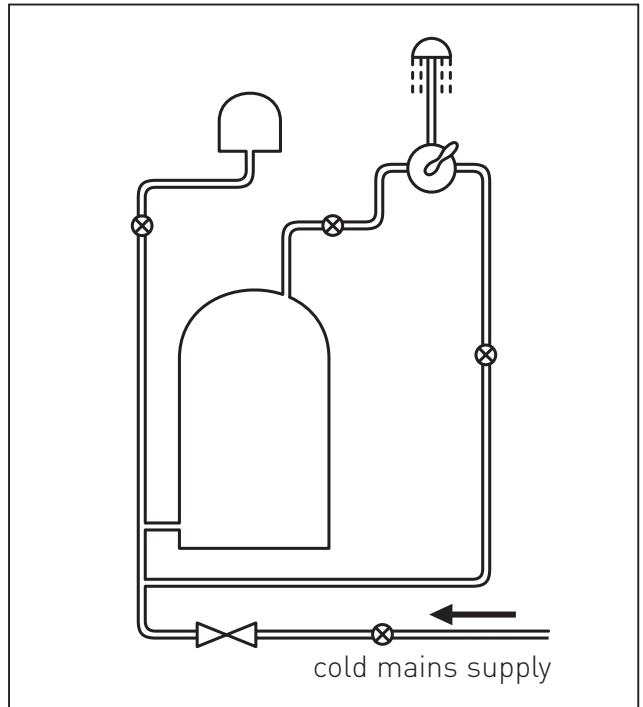

Pumped System

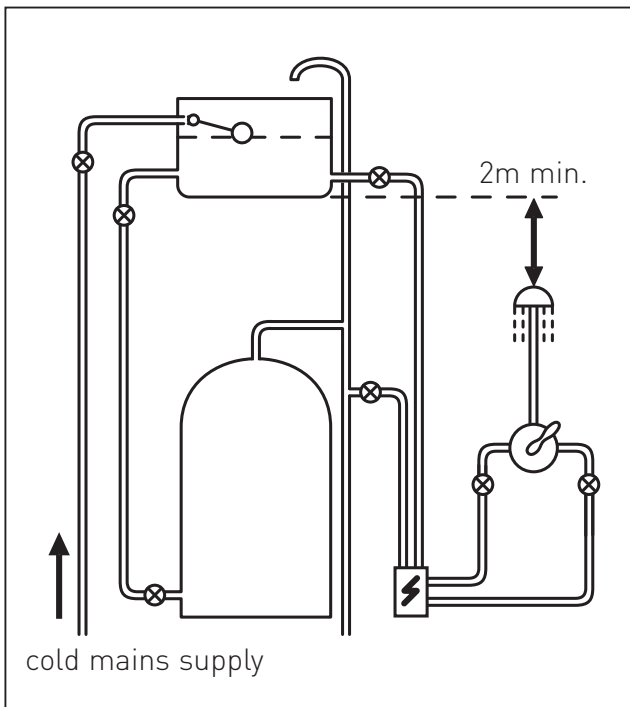

Pumped System (with Essex flange)

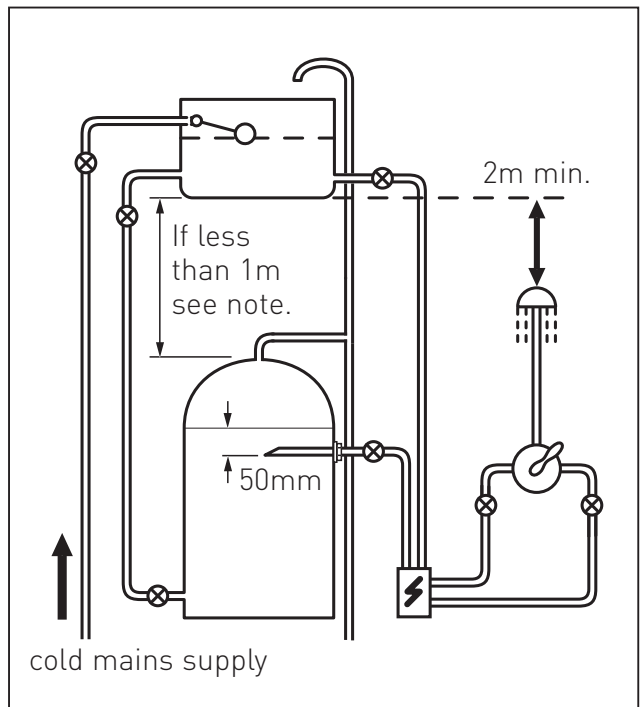

- Key:**  Isolating Valve  Reducing Valve  Shower Valve  Pump  Essex Flange

Installation Requirements

This fitting needs to be installed in accordance with the following Installation Requirements and Notes (IRN) to ensure they meet the requirements of the Water Supply (Water Fittings) Regulations 1999 and the Scottish Byelaws 2004.

IRN R001: See text of entry for Installation Requirements or Notes.

IRN R040 - Schedule 2-15 (1): The fitting shall be installed so that its outlet discharges above the spill-over level of any fixed appliance as indicated below:-

For backflow protection in domestic or installations up to, and including, Fluid Category 3.

If the fitting cannot be installed as indicated in the table opposite it shall be installed as either **a** or **b** below:

a: with an approved double check valve assembly or some other no less effective backflow prevention device immediately upstream of the inlet.

b: so that it draws water by gravity only from a cistern, or cylinder having a permanently open vent pipe, and the distributing pipe supplies no other fittings (other than a draining tap) at a lower level.

For backflow protection in premises or installations up to, and including Fluid Category 5.

The vertical distance of the outlet above the spill-over level shall be not less than 20mm or twice the diameter of the inlet pipe to the fitting, whichever is the greater. If the fitting cannot be installed as indicated it shall be installed with a backflow prevention arrangement suitable for the Fluid Category.

Size of tap or combination fitting	Vertical distance of outlet above spill-over level
1. Not exceeding ½"	20mm
2. Exceeding ½" but not exceeding ¾"	25mm
3. Exceeding ¾"	70mm

Installation Requirements

Conditions of use for Type 2 (Thermostatic mixer) valves

	High Pressure	Low Pressure
Maximum Static Pressure (Bar)	10	10
Flow Pressure, Hot & Cold (Bar)	0.5 to 5	0.1 to 1
Hot Supply Temperature (°C)	55 to 65	55 to 65
Cold Supply Temperature (°C)	Equal to or Less than 25	Equal to or Less than 25

Note: Valves operating outside these conditions cannot be guaranteed by the Scheme to operate as Type 2 valves.

If a water supply is fed by gravity then the supply pressure should be verified to ensure the conditions of use are appropriate for the valve.

Recommended outlet temperatures

The BuildCert TMV scheme recommends the following set maximum mixed water outlet temperatures for use in all premises:

41°C for showers.

The mixed water temperatures must never exceed 46°C.

The maximum mixed water temperature can be 2°C above the recommended maximum set outlet temperatures.

Note: 46°C is the maximum mixed water temperature from the bath tap. The maximum temperature takes account of the allowable temperature tolerances inherent in thermostatic mixing valves and

temperature losses in metal baths.

Warning: It is not a safe bathing temperature for adults or children.

The British Burns Association recommends 37 to 37.5°C as a  comfortable bathing temperature for children. In premises covered by the Care Standards Act 2000, the maximum mixed water outlet temperature is 43°C.

The thermostatic mixing valve (TMV) will be installed in such a position that maintenance of the TMV and its valves and the commissioning and testing of the TMV can be undertaken.

The fitting of isolation valves is required as close as is practical to the water supply inlets of the thermostatic mixing valve.

Installation Requirements

Conditions of use for Type 3 (Thermostatic mixer) valves

In order to give compliance with N.H.S. specification D08 the table below lists the conditions for normal use. These valves will perform adequately outside these parameters, however they cannot be guaranteed by the scheme to operate as Type 3 valves. If they are required to work with other supply conditions an engineer must carry out a risk assessment and satisfy themselves that the valves are suitable for use.

Normal Conditions of Type 3 valves

	High Pressure	Low Pressure
Maximum Static Pressure (Bar)	10	10
Flow Pressure, Hot & Cold (Bar)	1.0 to 5.0	0.2 to 1.0
Hot Supply Temperature (°C)	52 to 65	52 to 65
Cold Supply Temperature (°C)	5-20	5-20
Minimum Temperature Differential (°C)	10°C	10°C

This valve has been approved for use in the following designations.

Code	Operating Pressure	Application
HP-S	High Pressure	Shower
LP-S	Low Pressure	Shower

Key:

HP - High Pressure

LP - Low Pressure

The BuildCert TMV scheme recommends the following set maximum mixed water temperatures for use in all premises:

41°C for showers

The mixed water temperature must never exceed 46°C.

The maximum mixed water temperature can be 2°C above the recommended maximum set outlet temperatures.

Note: For wash basins, washing under running water is assumed.

Installation Requirements

Flow Regulators

This shower valve is fitted with a 7 litre per minute flow regulator in each water inlet which must be left in place when installed in conjunction with an instantaneous water heater/combination boiler.

Fitting both flow regulators and turning the water heater/combination boiler to its hottest setting, will ensure a sufficiently hot water supply to the shower valve during winter months (in the UK), when the mains cold water supply is at its coldest.

In the event that this shower valve is not installed with an instantaneous water heater/combination boiler, the flow regulators may be removed. Please follow the steps detailed to remove the flow regulators.

Note: If the flow regulators are removed the centre part of the regulator must be removed and the outer part fitted back into the inlets. See illustration (3).

Using a thin flat bladed screwdriver or similar tool, carefully prise the flow regulators out of both inlets (1 & 2).

With the flow regulators removed from the inlets, the plastic inserts (supplied) must be fitted as shown, with the small diameter first (3 & 4).

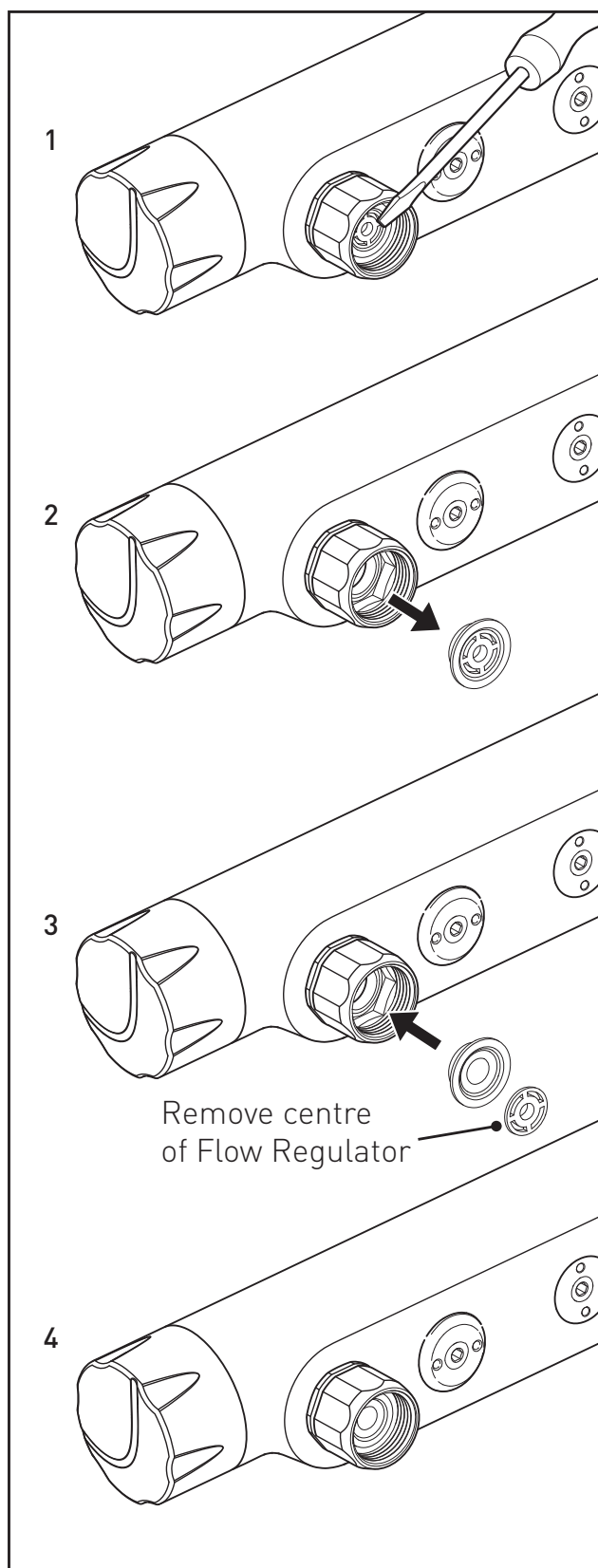

Installation - First Fix

Before Installation

Flush through the pipework to ensure removal of debris. Turn off the mains water supply and close any isolating valves.

1. Position fixing backplate

Identify the required position of the shower valve, where the wall mount fixing plate will be installed.

Mark a 230mm x 50mm rectangle on the wall surface.

Warning: Please check for any hidden electrical wires, cables or water supply pipes before drilling / cutting into the wall.

2. Prepare water supply pipes

The centres of the hot and cold water supply pipes should be 150mm apart, with a sufficient amount of pipework protruding through the wall.

3. Fit wall mount fixing plate

The wall mount fixing plate has two methods of fixing.

a) Tighten fixing lugs

Tighten the two screws in the middle of the fixing plate and the two either side of the inlets. Tightening these screws will secure the lugs against the inside of the wall surface.

b) Screw fixing plate to the wall

Using suitable screws for the wall type secure the wall mount fixing plate to the wall. There is a hole in each corner of the fixing plate for the fixings.

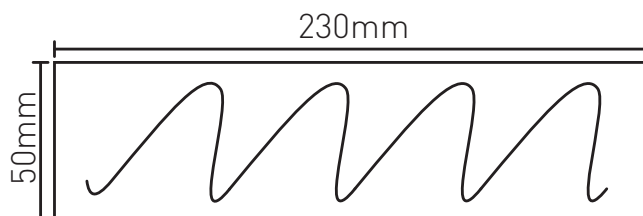

Important: Water supplies to the mixer must be with hot on the left and cold on the right when viewed from the front.

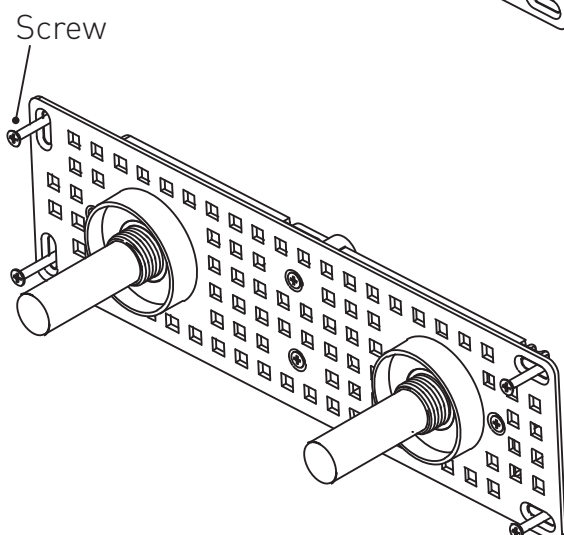
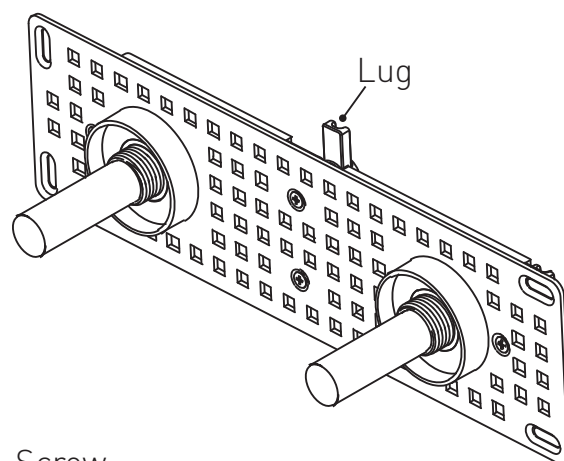

Installation - First Fix

4. Cut supply pipework

Once the wall mount fixing plate has been secured to the wall the water supply pipework will need to be trimmed back with the use of a pipe cutter.

Note: The supply pipework **must** protrude 10mm +/-2mm past the brass insert.

5. Attach olives and fixing bridges

Place olives (3) onto the protruding supply pipework.

Important: The pipework **must** protrude 10mm +/- 2mm past the brass inserts.

Screw the fixing bridges (4) onto the threaded brass inserts using a suitable spanner.

Note: If required, any decorating should be complete now before starting the second fix.

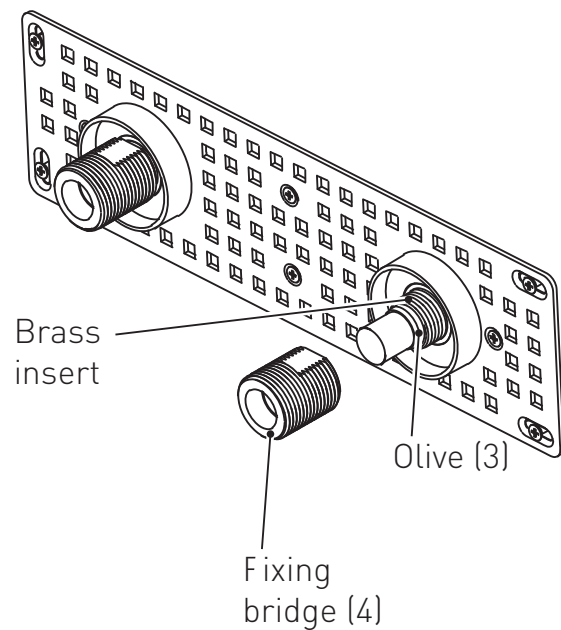
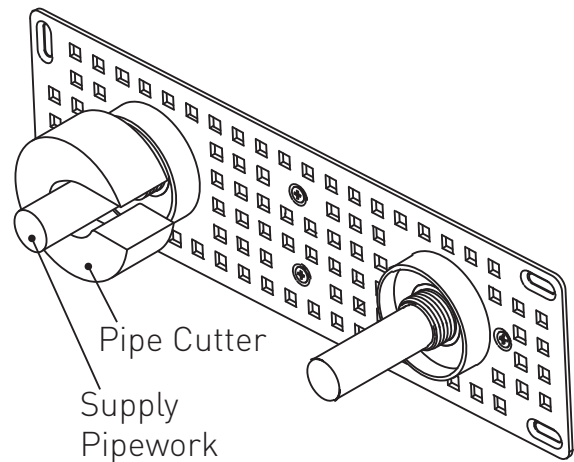

Installation - Second Fix

1. Fit covers

Screw the rear covers (5) onto the fixing bridges (4).

Note: The rear covers (5) screw onto the fixing bridges (4) flush up to the finished wall surface.

The front covers (6) slide up and down the shower valve fixing nuts to allow for different wall / tile thicknesses.

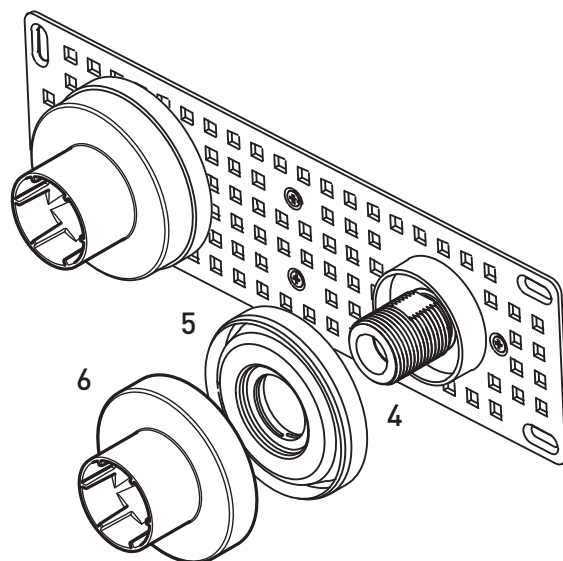

2. Attach shower valve

Place the filter washers (8) into the shower valve fixing nuts.

Position the shower valve (1) against the fixing bridges and carefully tighten the shower valve fixing nuts onto the fixing bridges.

The front shrouds (6) can be used to tighten the shower valve. Tighten fully by hand.

Note: Take care not to damage the finish of the shower valve fixing nuts. Protect the chromium plated surfaces with a cloth.

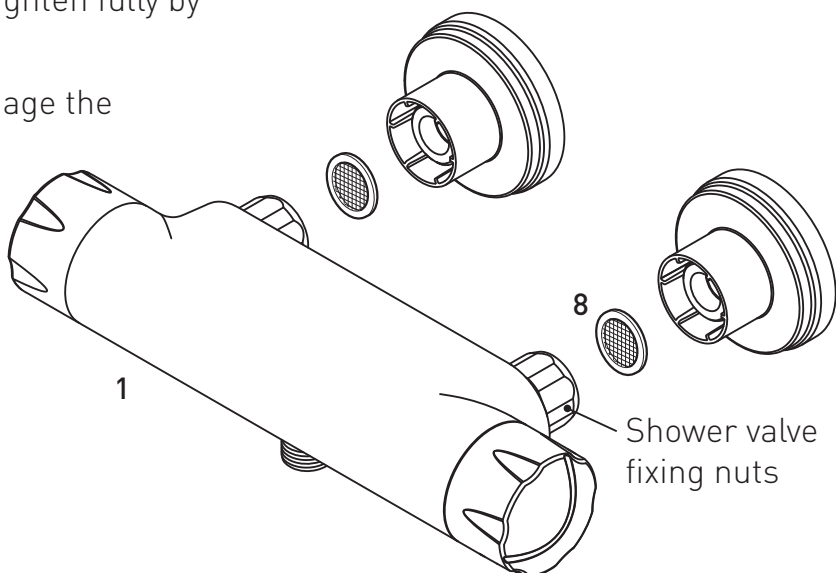

Operating the Shower

1. Temperature Control

Adjustable temperature control.

Turn the control clockwise to increase the temperature.

Turn the control anti-clockwise to decrease the temperature.

2. Water Flow Control

Controls the amount or flow of water from the showerhead.

Turn the control clockwise to turn on and increase the flow.

Turn anti-clockwise to reduce the flow and turn off.

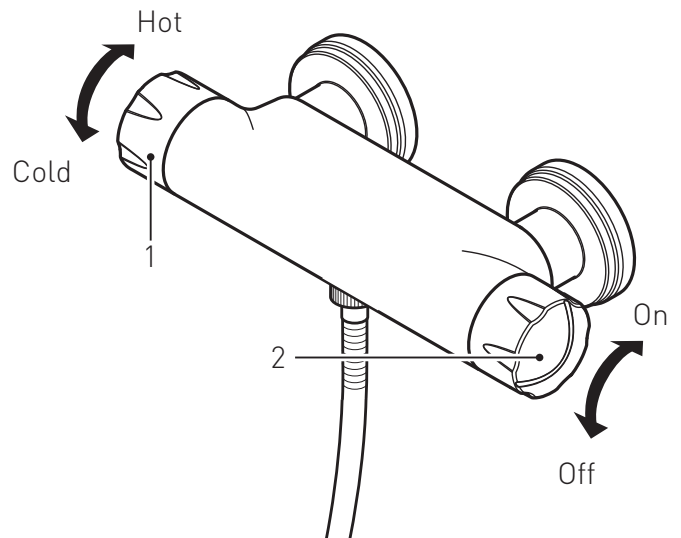

Commissioning

Commissioning notes for Thermostatic Mixing Valves

The first step in commissioning a thermostatic mixing valve is to check the following:

1. The designation of the thermostatic mixing valve matches the application.
2. The supply pressures are within the valves operating range.
3. The supply temperatures are within the valves operating range.
4. Isolating valves (and strainers preferred) are provided.

If all these conditions are met, proceed to set the temperature as stipulated in the Maintenance section.

The mixed water temperature at the terminal fitting must never exceed 46°C.

It is a requirement that all TMV2 approved valves shall be verified against the original set temperature results once a year. When commissioning / testing is due the following performance checks shall be carried out:

- Measure the mixed water temperature at the outlet.
- Carry out the cold water supply isolation test by isolating the cold water supply to the TMV, wait for five seconds, if water is still flowing check that the temperature is below 46°C.

If there is no significant change to the set outlet temperature ($\pm 2^{\circ}\text{C}$ or less change from the original settings) and the fail-safe shut off is functioning, then the valve is working correctly and no further service work is required.

Notes: If there is a residual flow during the commissioning or the annual verification (cold water supply isolation test), then this is acceptable providing the temperature of the water seeping from the valve is no more than 2°C above the designated maximum mixed water outlet temperature setting of the valve.

Temperature readings should be taken at the normal flow rate after allowing for the system to stabilise.

The sensing part of the thermometer probe must be fully submerged in the water that is to be tested.

Any TMV that has been adjusted or serviced must be re-commissioned and re-tested in accordance with the instructions in the Maintenance section.

The installation of thermostatic mixing valves must comply with the requirements of the Water Supply (Water Fittings) Regulations 1999.

In-Service Testing

Purpose

The purpose of in service tests is to regularly monitor and record the performance of the thermostatic mixing valve.

Deterioration in performance can indicate the need for service work on the valve and / or water supplies.

Procedure

Using the same measuring equipment or equipment to the same specification as used in the commissioning section, adjust the temperature of the mixed water in accordance with the manufactures instructions and the requirement of the application, Carry out the following sequence.

- a) Record the temperature of the hot and cold water supplies.
- b) Record the temperature of the mixed water at the largest draw-off flow rate.
- c) Record the temperature of the mixed water at a smaller draw-off flow rate, which shall be measured.

If the mixed water temperature has changed significantly from the previous test results (e.g. >1K), record the change and before re-adjusting the mixed water temperature check:

- a) That any in-line or integral strainers are clean.
- b) Any in-line or integral check valves or other anti-back siphonage devices are in good working order.

- c) Any isolating valves are fully open.

With an acceptable mixed water temperature, complete the following procedure:

- a) Record the temperature of the hot and cold water supplies.
- b) Record the temperature of the mixed water at the largest draw-off flow rate.
- c) Record the temperature of the mixed water at a smaller draw-off flow rate, which shall be measured.
- d) Isolate the cold water supply to the mixing valve and monitor the mixed water temperature.
- e) Record the maximum temperature achieved as a result of (d) and the final stabilised temperature.
- f) Record the equipment, thermometer etc. used for the measurements.

If at step (e) the final mixed water temperature is greater than 41°C and / or the maximum temperature exceeds the corresponding value from the previous results by more than about 2K, the need for service work is indicated.

Note: In-service tests should be carried out with a frequency, which identifies a need for service work before an unsafe water temperature can result. In the absence of any other instruction or guidance, the procedure described in Annex F of D 08 may be used.

In-Service Testing

Annex F of D 08 (informative)

Frequency of In-service tests

General

In the absence of any other instruction or guidance on the means of determining the appropriate frequency of in-service testing, the following procedure may be used:

- a) 6 to 8 weeks after commissioning carry out the tests in 'In-Service Tests'.
- b) 12 to 15 weeks after commissioning carry out the tests detailed in 'In-Service Tests'.

Depending on the results of the above tests, several possibilities exist:

- a) If no significant changes (e.g. <1K) in mixed water temperatures are recorded between commissioning and 6 to 8 week testing, or between commissioning and 12 to 15 week testing the next in-service test can be deferred to 24 to 28 weeks after commissioning.
- b) If small changes (e.g. 1 to 2K) in mixed water temperatures are recorded in only one of these periods, necessitating adjustment of the mixed water temperature, then the next in-service test can be deferred to 24 to 28 weeks after commissioning.
- c) If small changes (e.g. 1 to 2K) in mixed water temperatures are recorded in both these periods, necessitating adjustment of the mixed water temperature, then the next in-service test should be carried out at 18 to 21 weeks after commissioning.

d) If significant changes (e.g. > 2K) in mixed water temperatures are recorded in either of these periods, necessitating service work, then the next in-service test should be carried out at 18 to 21 weeks after commissioning.

Maintenance

General Cleaning

Your fitting has a high quality finish and should be treated with care to preserve the visible surfaces. All surfaces will wear if not cleaned correctly, the only safe way to clean your mixer is to wipe with a soft damp cloth. Stains can be removed using washing up liquid. All bath cleaning powders and liquids will damage the surface of your fitting, even the non-scratch cleaners.

Note: Never use abrasive detergents or disinfectants or those containing alcohol, hydrochloric acid or phosphoric acid.



Bristan recommend E-cloth for cleaning all of our bathroom & kitchen products. Using just water, E-cloth gives a smear free, deep clean by breaking up and holding dirt, which normal cloths leave behind. Order through your Bristan stockist (order code: ECLOTH).

Cartridge Maintenance

We advise that the shower valve is regularly serviced in hard water areas to maintain the flow of water.

Isolate both hot and cold water supplies to the shower valve by either:

- Turning the water supply off at the mains stopcock or
- Turning off the isolation valves to the shower valve

1. Remove the temperature control handle. undo the screw, remove the handle and plastic stop.

Important: The temperature stop only fits in one position.

2. Unscrew the locking nut anti-clockwise and remove the cartridge from the valve body.

3. Place the cartridge in a bowl and carefully add hot water (just off the boil) and vinegar to de-scale the cartridge. Leave in the solution until the water has cooled and rinse with clean water.

4. Grease the seals with a silicon grease supplied by Bristan (part number: SP-495-0002) and carefully refit the cartridge.

5. Replace the temperature stop and refit the handle.

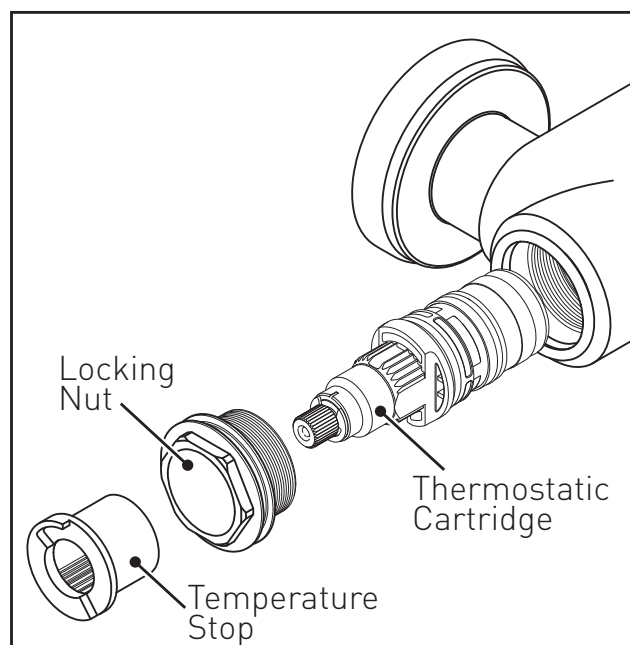

Maintenance

Adjusting the Temperature

The shower valve has been factory set with equal (balanced) hot and cold water supply pressures with the hot water supply at 65°C.

If your operating conditions are different from those above, the outlet water temperature may differ from the factory setting.

If required the shower valve can be re-calibrated to suit your own temperature requirements.

Turn the temperature control anti-clockwise (hotter) fully until it stops and check the temperature of the water with a thermometer. If the temperature is not correct, re-calibrate the shower valve:

1. Turn the flow of water on.
2. Remove the temperature control handle, undo the screw and carefully remove the handle but **do not** remove the plastic stop.
3. Turn the spline clockwise to decrease the temperature and anti-clockwise to increase the temperature. Check the temperature and adjust until you achieve the required temperature.
4. Replace the handle ensuring it is in the same position as when removed, against the the plastic temperature stop.
5. To finish, reinsert the screw and push on the cover.

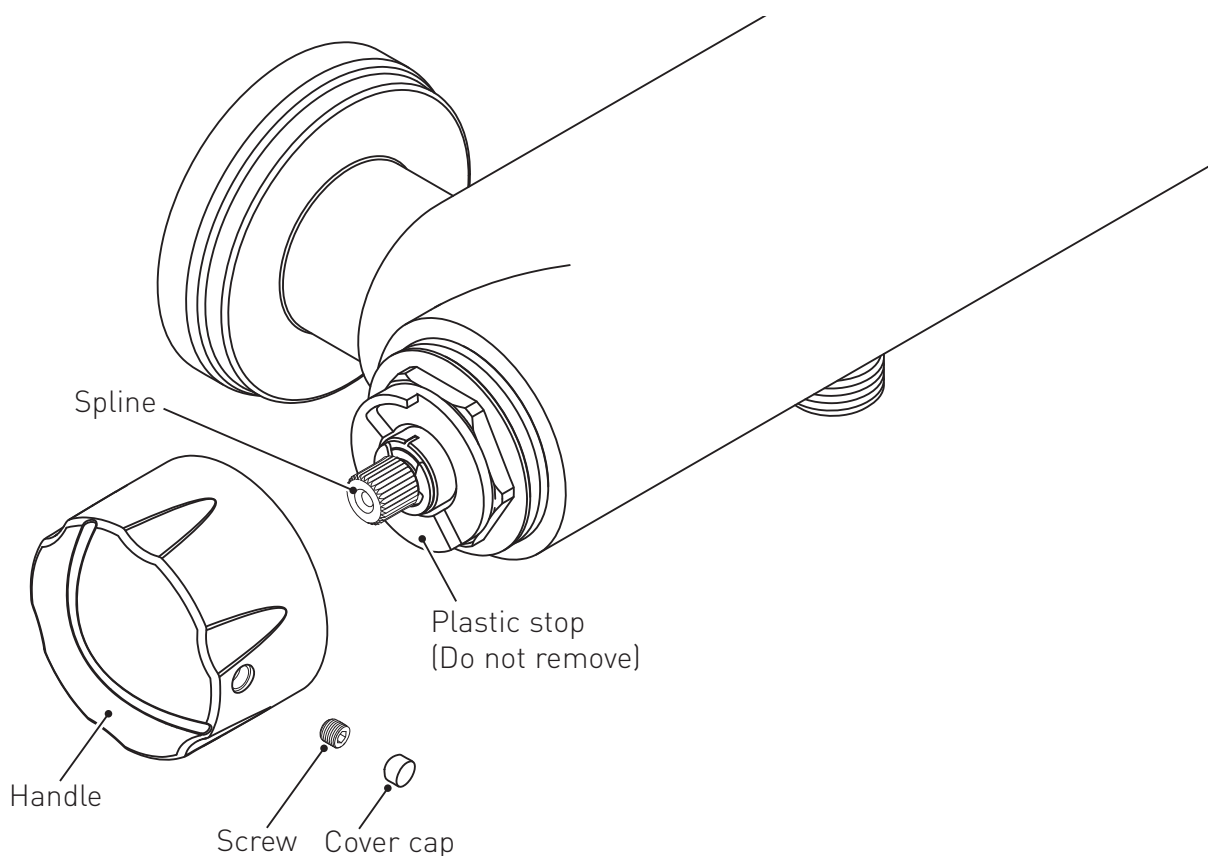

Maintenance

Thermal Disinfection Flushing

In order to kill off any build up of bacteria and to assist against legionella, this TMV has a built in cleansing feature that allows the mixed water passages to be flushed with hot water without the need to disassemble the shower valve or reset the mixed water temperature.

Due to different site conditions we recommend the periodicity of thermal disinfection flushing should be determined by current best practice.

To perform a hot water thermal disinfection flush of the TMV, the following should be carried out by a competent person.

1. Ensure the flow handle is in the 'Off' position with no water running from the TMV.
2. Using a 4mm hexagonal key close the cold water flushing isolator screw, turning clockwise until it stops completely.
3. Using a 4mm hexagonal key open the hot water bypass flushing screw, turning anti-clockwise until it stops completely.

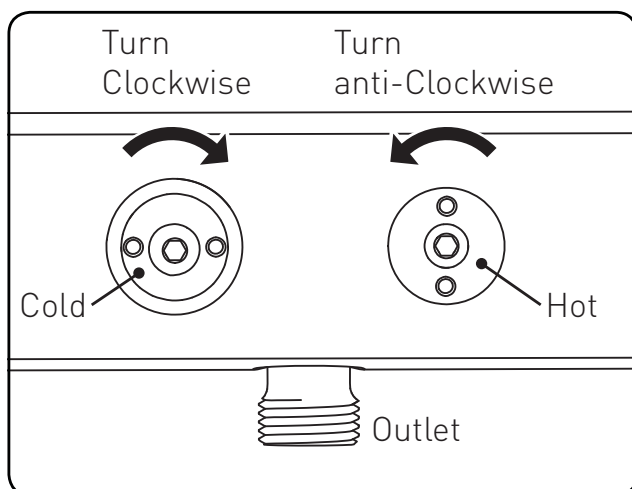

4. Turn the flow of water on by turning the flow handle to the 'On' position.
5. Hot water will flood the shower valve and exit the outlet. This is flushing the shower valve to remove any build up of bacteria. This flushing should be conducted inline with current best practice.
6. Turn the flow of water off by turning the flow handle to the 'Off' position.
7. Using a 4mm hexagonal key close the hot water bypass flushing screw, turning clockwise until it stops completely.
8. Using a 4mm hexagonal key open the cold water flushing isolator screw, turning anti-clockwise until it stops completely.

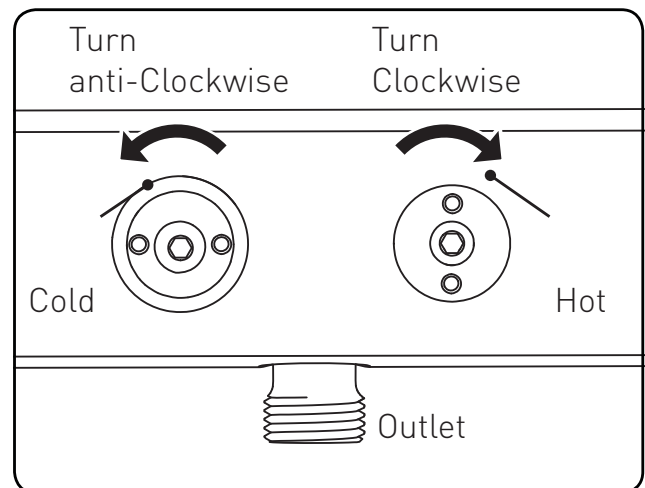

Run the valve and allow the mixed water to stabilise before use.

The thermal disinfection flushing is now complete and the TMV is now ready for normal use.

Troubleshooting

Symptom	Cause	Remedy
No flow or low flow rate and / or varying temperatures.	Partially closed stop or service valve in water supply pipework to the shower valve.	Open stop or service valve.
	Instantaneous water heater cycles on and off as the flow rate or pressure is too low.	Increase water flow rate or pressure through system. Contact the boiler manufacturer.
	Head of water is below the minimum distance required.	Raise the cistern or fit a shower booster pump.
	Inlet filter is partially blocked.	Clean or replace, flush through pipework before refitting.
	Hot or cold water being drawn off elsewhere causing pressure changes or instantaneous boiler temperature changes.	Do not use other water outlets when using the shower.
	Make sure the maintained inlet pressures are nominally balanced and sufficient.	Refer to Installation Requirements section (pages 10-15).
	Airlock or partial blockage of the pipework.	Flush through pipework to ensure removal of debris and any airlocks.
	No hot or cold water reaching the shower valve.	Check hot and cold feeds (the valve will shut down if either the hot or cold supply fails).
Maximum water temperature too hot or cold.	Maximum water temperature set incorrectly.	Reset maximum water temperature. Refer to 'Commissioning' (page 20) Refer to 'Adjusting the Temperature' (page 22).

Troubleshooting - cont.

Symptom	Cause	Remedy
Outlet water temperature too hot / cold.	Inlet filter is partially blocked.	Check insert filters for any blockages and clean as necessary.
	Installation conditions outside operating parameters.	Refer to Installation Requirements section (pages 10-15). Service shower valve as recommended. Refer to Maintenance section (pages 21-23). Refer to Adjusting the Temperature section (page 22).
Water temperature too cold.	Hot water temperature is less than 10°C above the required blend temperature.	Adjust hot water temperature or wait for water to reheat if stored system is used.
	Instantaneous water heater not igniting because water flow rate is too low.	Increase water flow rate through the system. Check cartridge inlet filters and clean or replace. Refer to Maintenance section (page 21-23). Contact the boiler manufacturer.
	Instantaneous water heater not igniting because water pressure is too low.	Increase water pressure through system. Contact the boiler manufacturer.
Only hot or cold water from shower valve outlet.	Inlet water supplies are reversed (hot to cold supply).	Check the connections are the correct way round. Hot on the left and cold on the right when viewed from the front. Rework pipework as necessary.
	Inlet filter is partially blocked.	Clean or replace, flush through pipework before refitting.

Notes

Please use this space to add any notes you or your installer may have regarding the plumbing system / installation of this product.

Notes

Please use this space to add any notes you or your installer may have regarding the plumbing system / installation of this product.

Guarantee

At Bristan, we want to make things as easy as possible for our customers. That's why we design products that are easy to fit and use, and that are quality tested to make sure they won't let you down. It's also why we offer solid guarantees on all products, effective from the date of purchase, to give you peace of mind.

All Bristan Commercial Shower Valves are covered by a 1 year guarantee. This also includes 1 year labour cover which means that, in the unlikely event that there is a problem in the first year after purchase, we'll send one of our expert engineers to fix it.

*Labour is provided by an approved Bristan Care engineer or appointed representative. The guarantee only applies to products with a manufacturing fault. There will be a call out charge for any incidents where no fault has been found with the product, or if the issue is due to poor installation or maintenance.

Guarantee Terms and Conditions

This guarantee is in addition to your statutory and other legal rights and is subject to the following conditions:

- The product was purchased within the United Kingdom or Republic of Ireland.
- The guarantee applies solely to the original purchaser with proof of purchase.
- The installation must allow ready access to all products for the purpose of inspection, maintenance or replacement.

- Repair under this guarantee does not extend the original expiry date. The guarantee on any replacement parts or product ends at the original expiry date

- Any part found to be defective during the guarantee period will be replaced without charge, providing that the product has been installed in accordance with the instructions given in this guide and used as the manufacturer intended.

The guarantee does not cover

- Damage or defects caused by:
 - General wear and tear (including special non-chrome finishes;
 - Components such as filters, seals, 'O' rings and washers)
 - Incorrect installation
 - Repair using non-Bristan part
 - Accidental or wilful misuse
 - Corrosion and the use of inappropriate cleaning products.
 - System debris including the build up of limescale (which can be controlled through regular servicing and maintenance)
- Compensation for loss of use of the product or consequential loss of any kind.

In the interests of continuous product improvement, Bristan reserves the right to alter product specifications without notice.

The Bristan Product Guarantee does not affect your statutory rights as a consumer.

Guarantee & Service Policy

Need help?

If this product does not function correctly when first used, contact Bristan Care Customer Service on 0844 701 6273 where our expert team of advisors will be able to offer you help and advice.

Problems during the guarantee period

In the unlikely event that you encounter any problems with the product during the guarantee period, contact Bristan Care Customer Service on 0844 701 6273 with your proof of purchase and we will work to resolve the problem quickly.

Bristan Care Customer Support

Bristan customers also benefit from the support of Bristan Care, our comprehensive customer support package which offers:

Technical support hotline

(Tel: 0844 701 6273) with access to fully trained advisors who can offer installation advice, talk you through quick maintenance checks, or recommend the best course of action to fix any problems with a product

Expert advice

Find easy to follow 'how to' video guides and technical FAQs online at www.bristan.com. Our guides take you step-by-step through many product installations and you can find plenty of easy guides to quick product fixes and servicing.

Spare parts

We hold thousands of spares and we keep them for discontinued products for over seven years. Spares can easily be ordered online at www.bristan.com and are dispatched the same day.

Expert plumbing engineers

If we can't solve the problem over the 'phone or with a spare part, then we'll send out one of our Bristan Care engineers to take a look. Bristan Care engineers provide free support for products that are within guarantee, but are also available to service products that are out of guarantee for a small charge. For details, please call customer services on 0844 701 6273.

Part Number: FI OP SHXVO
Issue: D1

BRISTAN

Bristan Group Ltd.
Birch Coppice Business Park
Dordon
Tamworth
Staffordshire
B78 1SG
Web: www.bristan.com
Email: enquire@bristan.com

A Masco Company

Useful contact details:

Customer Service:

0844 7016273

Customer Service Email:

Customercare@bristan.com

Customer Service Fax:

0844 7016275

Reception:

0844 7016274

Join us on...



TECHNICAL DATASHEET

COMMERCIAL

OPAC THERMOSTATIC EXPOSED BAR SHOWER VALVE WITH FAST FIT CONNECTIONS

Product Specification



Product Code:	OP SHXVO EH C
Finish:	Chrome
Product Type:	Commercial
Construction:	Body is of brass construction and is designed to conform to BS EN 1111:1999 (HP) & BS EN 1287:1999 (LP)
Valve Type:	Thermostatic Cartridge
Supply:	Suitable for all plumbing systems (Preferably balanced)
Inlet Connections:	15mm compression fast fit connections
Outlet Connections:	½" BSP
Working Pressures:	Min 0.2bar, Max 5.0bar Maximum Static Pressure: 10.0 bar
Dimensions for Fitting:	150mm inlet centres

Additional Information

- Cool touch shower valve body for ultimate user safety.
- Easy installation with first/second fix fixing kit.
- Integral isolator & flushing mechanism for easy maintenance.
- High performance at low pressures.
- TMV2 & TMV3 approved.
- Complies with D08 specification.

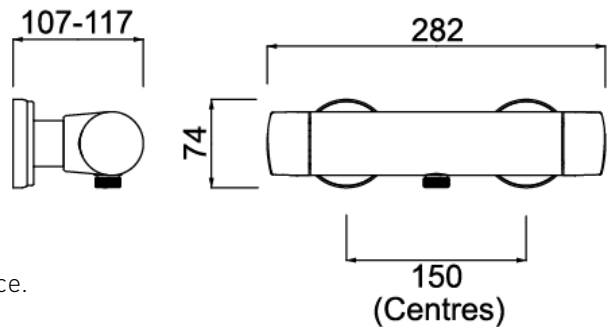

Technical Advice: For further information please call 0844 7016273 or email customercare@bristan.com

Guarantee: 1 year covering manufacturing faults.

Compliance / Approvals

WRAS: Certificate N^o: 1409054

TMV2: Certificate N^o: BC1397/0714 **TMV3:** Certificate N^o: BC1402/0614

Flow Rates (litres per minute)

System Pressure	0.2bar	0.5bar	1bar	2bar	3bar	4bar	5bar
With Flow Regulators Fitted	-	9.4	9.5	11.3	11.8	11.7	11.4

Bristan, Birch Coppice Business Park, Dordon, Tamworth, B78 1SG
 Telephone: 0844 701 6274 Facsimile: 0844 701 6275
 Web Site: www.bristan.com Email: enquire@bristan.com



Guarantee

Delivery

0844 7016273

D2

