

Application

For built-in furniture doors sliding on a double track, i.e. wardrobes and cupboards in residential heavy duty applications.

Easy door height adjustment.

Silent operation - nylon wheeled bearing hangers and aluminium track.

Door Specification

Track System:	Wardrobe Double 50
For Individual Doors:	
Max Door Height	2400mm
Max Door Width	900mm
Max Door Weight	50kg
Door Thickness	16-35mm

Lightly framed timber doors or doors made from medium density fibreboard (MDF) must have provision for hangers to be screwed securely to the back face of the doors

Standard Sets and Packs

Sets comprise top track, hangers, door stop(s), sawcut guide(s), all screws and fitting instructions.

Set No.	Opening width	Track Length	Hardware for
WD50-12/2	1200mm	1200mm	2 doors
WD50-15/2	1500mm	1500mm	2 doors
WD50-18/2	1800mm	1800mm	2 doors
WD50-24/3	2400mm	2400mm	3 doors

Pack No.	Application
WD50-2PK	2 door pack of fittings only, without track
WD50-3PK	3 door pack of fittings only, without track

Hardware Specification

Track :	52
Material	Aluminium
Standard lengths	1200mm, 1500mm, 1800mm, 2400mm, 3000mm, 3600mm and 4800mm

Hangers (2 per door): 550, 551, 552
Nylon tyred ball race wheel with zinc plated plates face fitted to the back of the door. Vertical adjustment 10mm.

Door Stop: 28N
Nylon safety door stop prevents fingers being jammed on bi-passing doors.

Guide: 55GD
Nylon surface-fixed guide included in sets and packs. Alternative guides available, as shown here and overleaf.

Alternative Guide 101N
Nylon sawcut guide. Alternative to 55GD sawcut nylon guide.

Accessories:
Channel and Guide 81 and 113N/81
113N/81 guides in white nylon. For heavy duty applications or where more than 3 doors are required per opening. 81 channel, aluminium, available in 1200mm, 1500mm, 1800mm, 2400mm, 3000mm and 3600mm lengths.

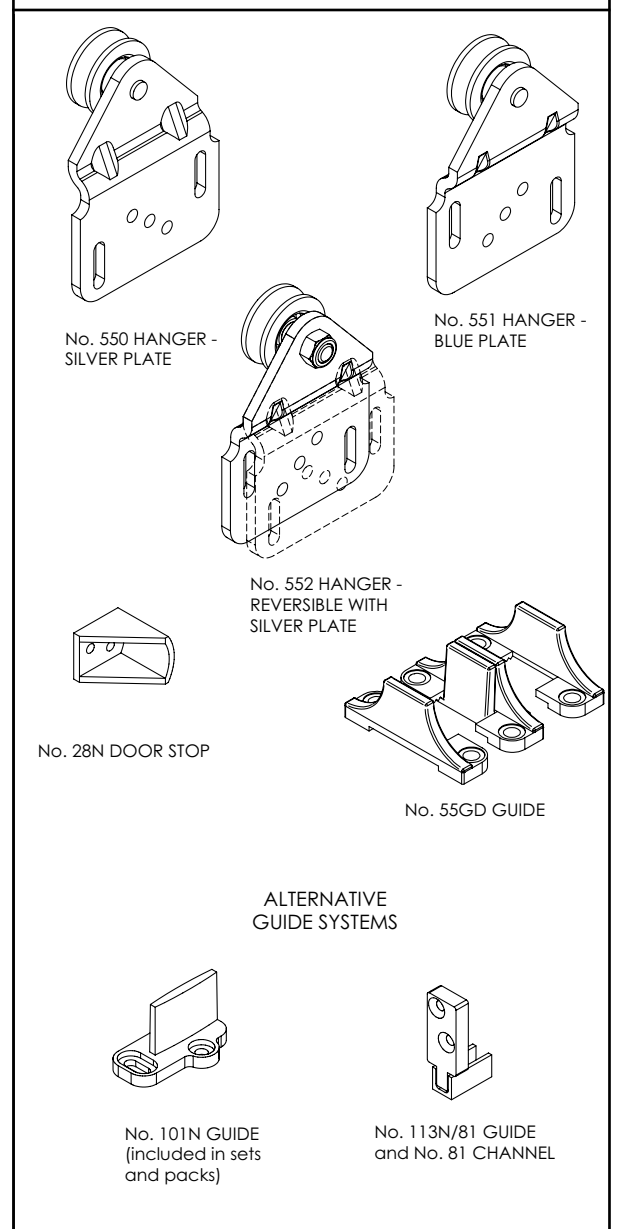
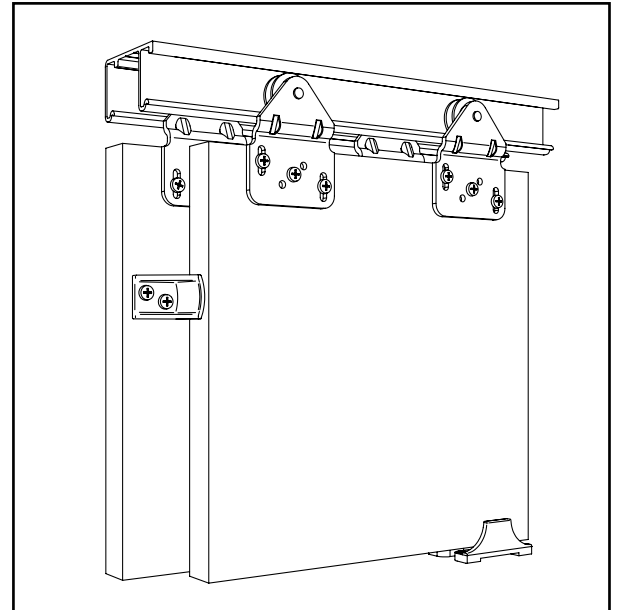

DOOR THICKNESS	19	22	25	29	32	35	38	40
DIMENSION 'A'	4	16	19	23	26	29	20	22
DIMENSION 'B'	9	23	20	16	13	10	8	8
DIMENSION 'C'	0	4	7	11	14	17	20	22

DOORS 19 THICK & UNDER

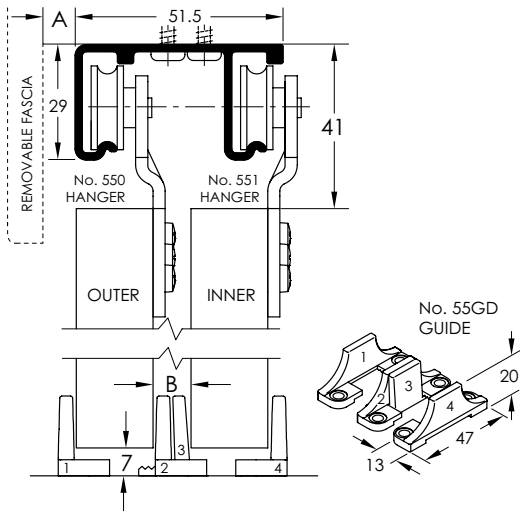

DOORS 20 TO 35 THICK

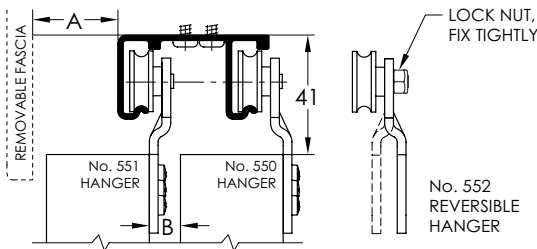

TRIPLE LINE DOORS 35 THICK & UNDER

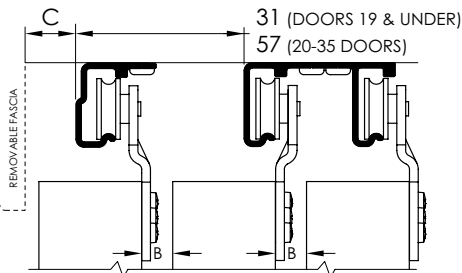

NOTE: 22-35 THICK DOOR HANGER ORIENTATION SHOWN. FOR 16-19 THICK DOORS HANGER ORIENTATION TO BE AS SHOWN IN FIRST IMAGE.

ALTERNATIVE FLOOR GUIDES

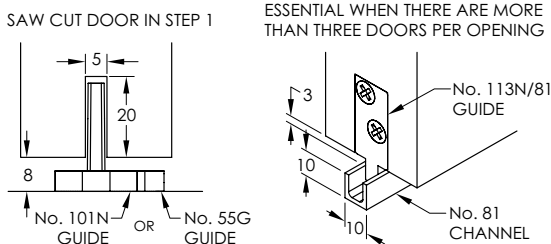

1 Prepare Doors

Door width = (Opening width / No. of Doors) + 5 to 10mm (Overlap)
 Door height = Opening height less 53mm.
 Track length = Opening width
 For more than three doors use continuous channel and guide.

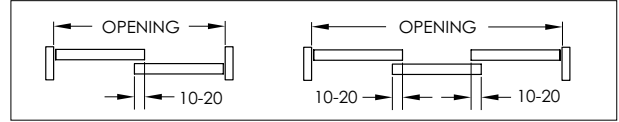

2 Fit Track

Door thickness determines dimension 'A' - see table. Fit track 'A' mm from the outside edge of a level and flat lintel. For triple line systems fit tracks as shown, use dimension 'C' from table.
 For doors over 35 thick use multiple 51 tracks.

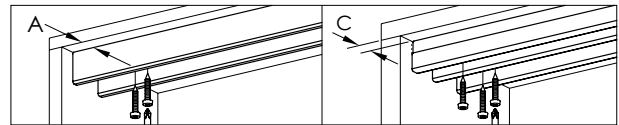

3 Fix Hardware to Door

Doors 19mm thick and less- fit blue plate hangers to inner door. All other thicknesses, the blue hangers are fitted to the outer door. Align the plate shoulder with the top edge of the door. Screw 2 screws only in the centre of the slotted holes to give ±5mm vertical adjustment.

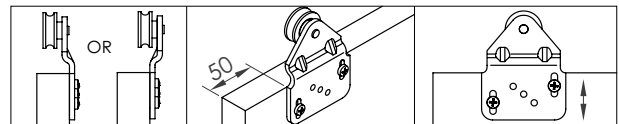

4 Fit Doors & Adjust

Working inside to out. Hook doors onto track. Adjust hangers to obtain maximum floor clearance. When doors are hanging plumb and square, fit a 3rd screw into one of the hanger locating holes.

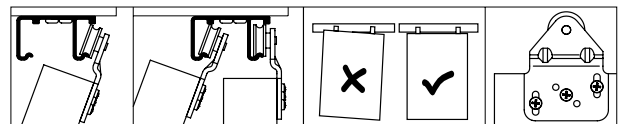

5 Fit Guide

With doors hanging plumb fix guide to overlapping area of opening. Screw holes under door. Slide to doors one side of opening and secure guide with one screw in the visible holes. Position components 2 & 3 of guide to dimension 'B'. Slide doors to opposite side and fit remaining screws.

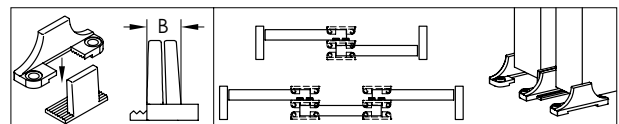

6 Fit Door Stop

Position door stop on inner face of outer door 2/3 of door height. Positioned to prevent finger pull from passing the edge of adjacent door (not supplied).

