

# Thermostatic Bar Valve

---

## **INSTALLATION & AFTERCARE INSTRUCTIONS**

Suitable for the installation of:

Single Outlet Bar Valve  
Dual Outlet Bar Valve  
Cool Touch Bar Valve

---

## INTRODUCTION

Thank you for choosing this product. This guide covers the installation and commissioning of the shower valve.

Your bar shower valve is a thermostatic mixer which incorporates a thermo-regulating cartridge to assure users of consistent showering temperatures. The valves have been designed & manufactured to comply with both BS EN1287:1999 (low pressure) or BS EN 1111:1999 (high pressure) operating conditions.

---

## OPERATING CONDITIONS OF USE

Before installation the operating conditions of use must be checked. The table below contains details of the necessary conditions of operation. This valve is suitable for use with the following systems:

- Gravity fed Hot & Cold (equal pressures)
- Gravity fed Hot & mains Cold (equal pressure)
- Unvented systems
- Gas combination boiler
- Pumped system

Note: If water supply is fed by gravity then supply pressure should be verified to ensure the conditions of use are appropriate for the valve

	High Pressure	Low Pressure
Max Static Pressure - BAR	10	10
Flow Pressure (Hot and Cold) - BAR	1 - 5	0.1 - 1
Hot Supply Temperature - °C	55 - 65	55 - 65
Cold Supply Temperature - °C	≤ 25	≤ 25

---

## VALVE INSTALLATION GUIDELINES AND COMPLIANCE

The valve must be installed so that it is readily accessible for commissioning and maintenance. The valve must be installed with isolation valves on both the hot and cold water systems as close as possible to the valve; so as to allow the valve to be commissioned and tested correctly. The valve is fitted with integral check valve cartridges which command the water supply, therefore the thermostatic valve is protected against cross-flow due to unbalanced line pressures as required by the Water Supply (Water Fittings) Regulations 1999.

This shower valve must be installed in accordance with the Water Supply (Water Fittings) Regulations 1999. We recommend this product should only be fitted by a qualified plumber. The valve must be installed in accordance to the following Installation Requirements and Notes (IRN):

### IRN R010

Water supplies shall be at reasonably balanced pressures from a common source (e.g. hot and cold supplies both from the same storage or both from a supply pipe). Where the fitting is supplied from unbalanced supplies (e.g. hot and cold supplies from separate sources) an 'Approved' single check valve or some other no less effective backflow prevention device shall be fitted immediately upstream of both hot and cold water inlets.

# IRN R040

## Schedule 2-15 (1)

The fitting, or outlet supplied by the fitting, shall be installed so that its outlet discharges above the spill-over level of any fixed appliance as indicated below:

For backflow protection in domestic premises or installations up to, and including, Fluid Category 3.

Size of Tap or Combination Fitting	Vertical Distance of Outlet Above Spill Over Level
1. Not exceeding 1/2in	20mm
2. Exceeding 1/2in but not exceeding 3/4in	25mm
3. Exceeding 3/4in	70mm

**If the fitting cannot be installed as indicated in the table above it shall be installed: -**

a) with an approved double check valve assembly or some other no less effective backflow prevention device immediately upstream of the inlet; or

b) so that it draws water by gravity only from a cistern, or cylinder having a permanently open vent pipe, and the distributing pipe supplies no other fittings (other than a draining tap) at a lower level.

### **For backflow protection in premises or installations up to, and including Fluid Category 5.**

The vertical distance of the outlet above the spill-over level shall be not less than 20 mm or twice the diameter of the inlet pipe to the fitting, whichever is the greater.

If the fitting cannot be installed as indicated it shall be installed with a backflow prevention arrangement suitable for the Fluid Category.

### **Taps incorporating a hose union outlet**

If the outlet of the tap assembly is designed to accommodate the attachment of a flexible hose and therefore potentially compromise the required AUK3 air gap, alternative Fluid Category 5 backflow protection is required, as the AUK3 air gap provided by the tap would not apply.

## INSTALLATION

Most problems associated with the operation of thermostatic shower valves are caused by debris in the new pipe work getting into the thermostat. These problems are easily avoided by thoroughly flushing the pipe work BEFORE the shower valve is fitted.

We recommend this product is fitted by a qualified plumber. Wear suitable eye protection when drilling. Take care when using power tools near water - the use of a residual current device (RCD) is advised. Beware of hidden cables or pipes. When drilling tiled surfaces, a piece of masking tape applied to the wall before marking out the fixing holes will stop the drill wandering.

Before commencing installation, first determine which shower system you have from the options below and overleaf, and follow the associated instructions.

For installation of bar valves supplied with quick fixing kit:

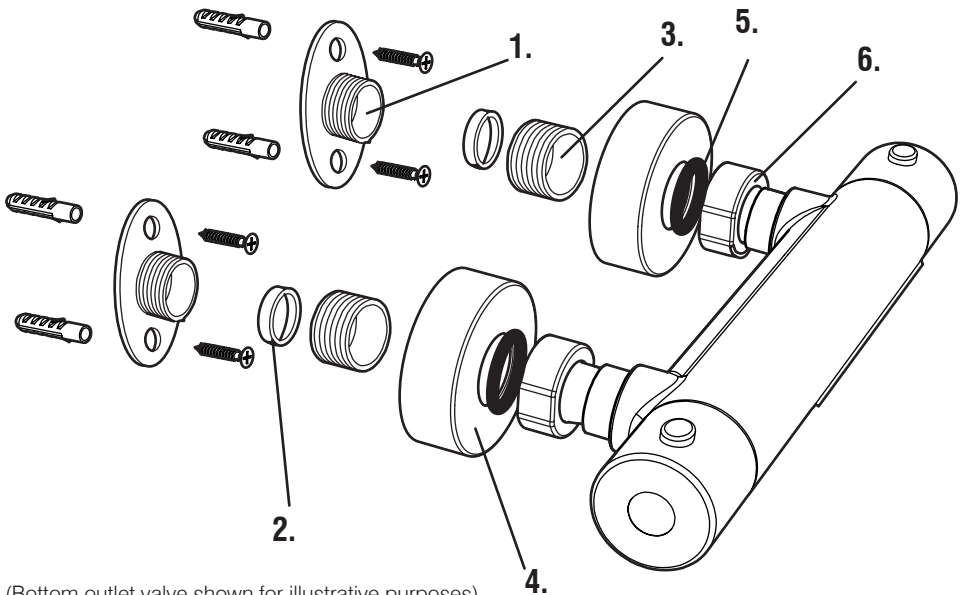

(Bottom outlet valve shown for illustrative purposes)

1. Install hot and cold inlet pipework (15mm) to the desired installation location - ensuring the pipes are 150mm apart and protude at least 35mm from the finished wall surface.
2. Mount the quick fixing wall plate(1.) to the wall over the pipework using the fixings provided
3. Insert the olives (2.) over the pipework and tighten the compression thread (3.) onto the wall plate. This will compress the olive and secure it to the pipework.
4. Thread the trim ring (4.) onto the compression thread to cover up the wall plate fixings.
5. Ensuring that the rubber washer (5.) is inserted between the bar valve and the compression thread, mount the bar valve using the swivel nuts. Check the system for leaks before commissioning.

---

For installation of bar valves with offset threaded connectors:

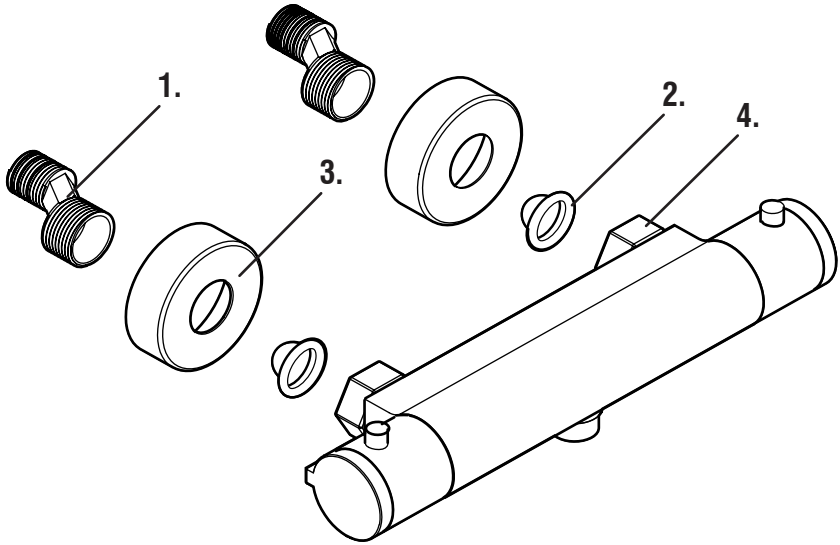

**(Bottom outlet valve shown for illustrative purposes)**

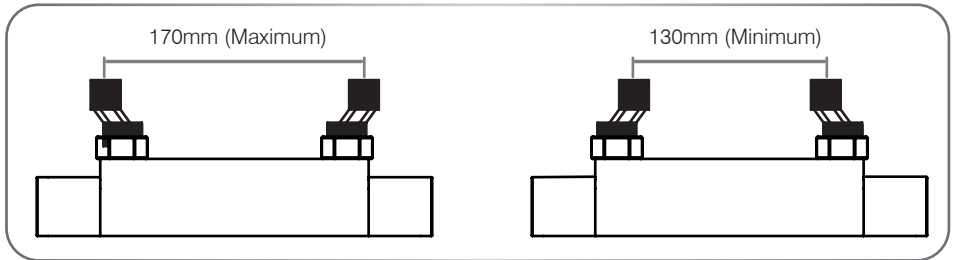

1. Install hot and cold inlet pipework (15mm) to the desired installation location. Standard bar valve centres are 150mm apart.
  2. Attach the offset threaded connector (1.) to the pipework. The hole centres are adjustable between 130mm and 170mm to suit the installation at hand.
  3. Insert the filter gasket (2.) into the threaded connector and assemble the cover shroud (3.) to the threaded connector.
  4. Mount the bar valve using the swivel nuts (4.) Check the system for leaks before commissioning.
-

---

For installation of bar valves with additional accessory shelf:

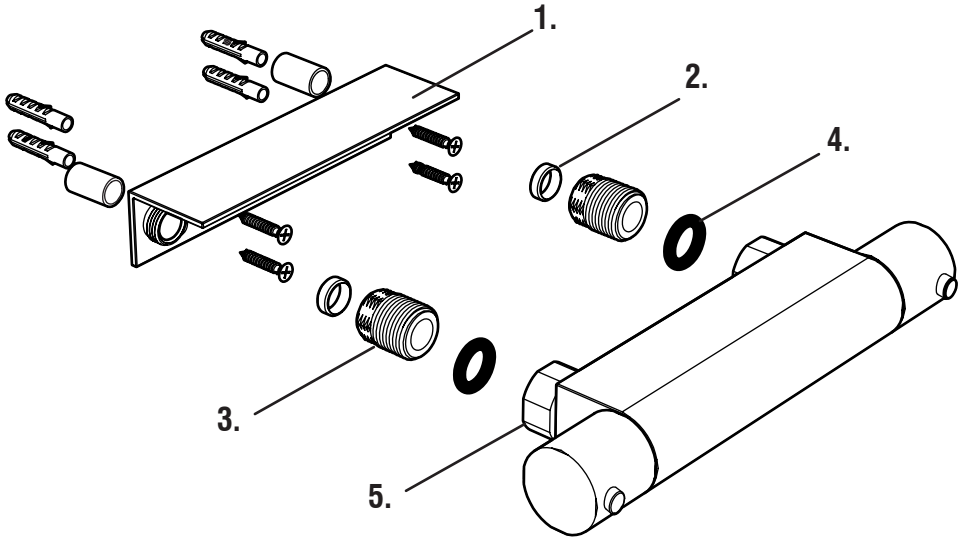

1. Install hot and cold inlet pipework (15mm) to the desired installation location - ensuring the pipes are 150mm apart and protude at least 35mm from the finished wall surface.

2. Mount the wall bracket shelf (1.) to the wall over the pipework using the fixings provided

3. Insert the olives (2.) over the pipework and tighten the compression thread (3.) onto the wall plate. This will compress the olive and secure it to the pipework.

4. Ensuring that the rubber washer (4.) is inserted between the bar valve and the compression thread, mount the bar valve using the swivel nuts (5.) Check the system for leaks before commissioning.

---

---

## SETTING MAXIMUM VALVE TEMPERATURE

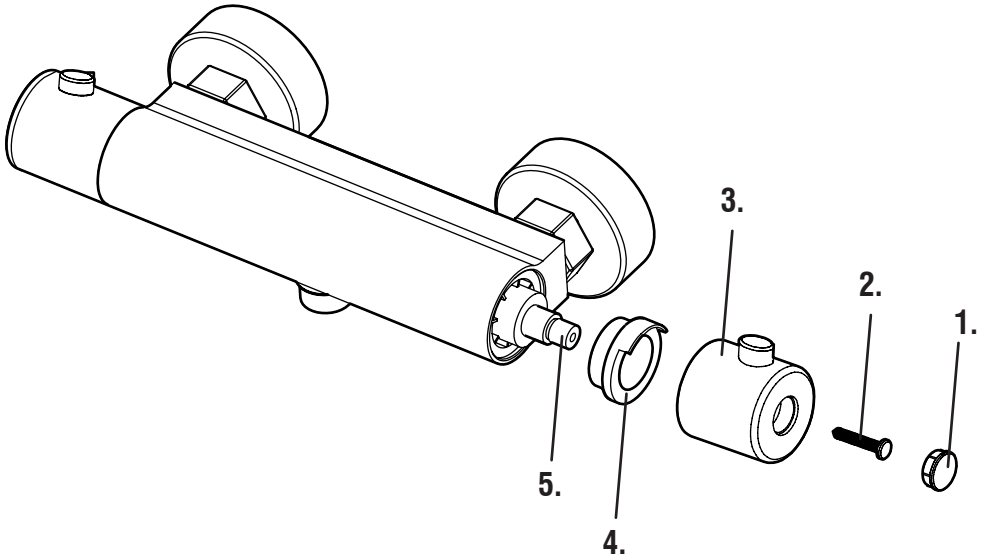

**(Valve shown used for illustrative purposes - cool touch valve has temperature handle on opposite side)**

This bar valve is factory set with the temperature stop set at max. 42-44°C.

Only if the maximum temperature needs to be adjusted, follow the instructions below:

1. Remove the end cap (1.) from the temperature handle.
2. Remove the screw (2.) and remove the handle (3).
3. With the temperature stop (4.) still fitted to the cartridge spindle (5.) turn the cartridge spindle to adjust the water temperature. Turning anticlockwise will increase the maximum temperature output setting whilst turning the spindle clockwise will decrease it.
4. Refit the handle so the stop of the handle meets the right hand side of the stop on the temperature stop.
5. Turn on the flow control handle and wait for a few moments. Test the temperature of the water.

Repeat until maximum temperature output is 44°C / 111.2 F

---

## TESTING AND ANNUAL SERVICING

It is recommended that showers do not exceed 44°C. The valve temperature should never exceed 46°C. Carry out the cold failure test to ensure the valve operates at the correct outlet temperature.

The valve should be tested to ensure correct operation at installation and thereafter at stated intervals decided by the user but never at greater than 12 monthly intervals. The testing will only require a normal thermometer with a scale greater than 65°C. The temperature sensitive element of the thermometer should always be fully inserted into the water flow.

Follow the procedure below:

1. Measure the mixed water temperature.
2. Carry out a cold fail/safe shut-off test by using the mains isolation valve to shut off the water to the cold supply. Wait 5 seconds, if water is still flowing check that the water temperature is below 44°C. The flow should stop or reduce to a trickle.
3. Open the cold water isolation valve and measure mixed water temperature. If there is no significant change from the original settings and fail/safe shut off is functioning the valve is working correctly and no further service is required. If the outlet temperature has drifted by more than 2°C, or if the fail/safe function does not work, a full service or re-commissioning is required. We recommend that in these circumstances you contact a plumber for advice as servicing should only be undertaken by a competent person.

---

## TROUBLE SHOOTING

If you require further assistance beyond the guide below, please contact customer services using the contact details on the back of this guide

PROBLEM	SOLUTION
After installation, shower only runs hot or cold - there is no mixed water.	Hot & cold supplies are plumbed the wrong way around.
Shower will not run hot enough when first installed.	The maximum temperature needs to be adjusted - see the temperature setting guide in this manual.
Cold water is running back through the valve and into the hot water system.	Check and clean the check valve cartridges and filters located under the check valve. These may need to be replaced.



# Shower Riser Kits

## INSTALLATION & AFTERCARE INSTRUCTIONS

Please retain for future reference

This guide provides instruction for the installation operation and maintenance of a variety of shower riser kit systems. Product appearances may vary, but the installation methods are similar. Please follow the valve installation instructions before installing any riser kits.

We recommend these products are installed by a qualified plumber. Some diagrams are for illustrative purposes only and actual product may differ slightly. In the unlikely event you find there are parts missing please contact customer services using the contact details at the foot of the page.

### IMPORTANT

Wear suitable eye protection when drilling. Take care when using power tools near water - the use of a residual current device (RCD) is advised. Beware of hidden cables or pipes. When drilling tiled surfaces, a piece of masking tape applied to the wall before marking out the fixing holes will stop the drill wandering.

### INSTALLATION

1. If the shower handset slider is not pre-assembled to the rail, ensure this is assembled before fastening the riser rail to the pre-installed bar valve, as shown in the options below.

For round riser rail fixings with 1/2" threaded connections, ensure to place a piece of fabric between the spanner & fixing nut to prevent possible damage to the chrome finish (A.)

For square bar valve systems, remove the grub screw cover cap and loosen the grub screw at the bottom of the riser rail. Slide the riser rail assembly onto the bar valve top outlet and secure in place with the grub screw. Replace the grub screw cover cap (B.)

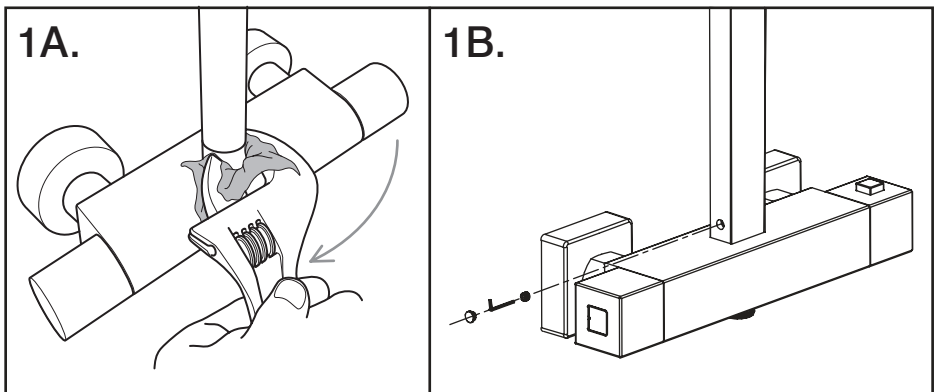

2. Measure the distance (X) from the valve to the location of the wall bracket and mark the location of the wall bracket on the wall with a pencil. Drill an appropriately sized hole for the fixings supplied in the finished wall surface. Wall plugs provided are suitable for stone or brick walls. For other wall types use appropriate wall plugs. If in doubt consult an expert.

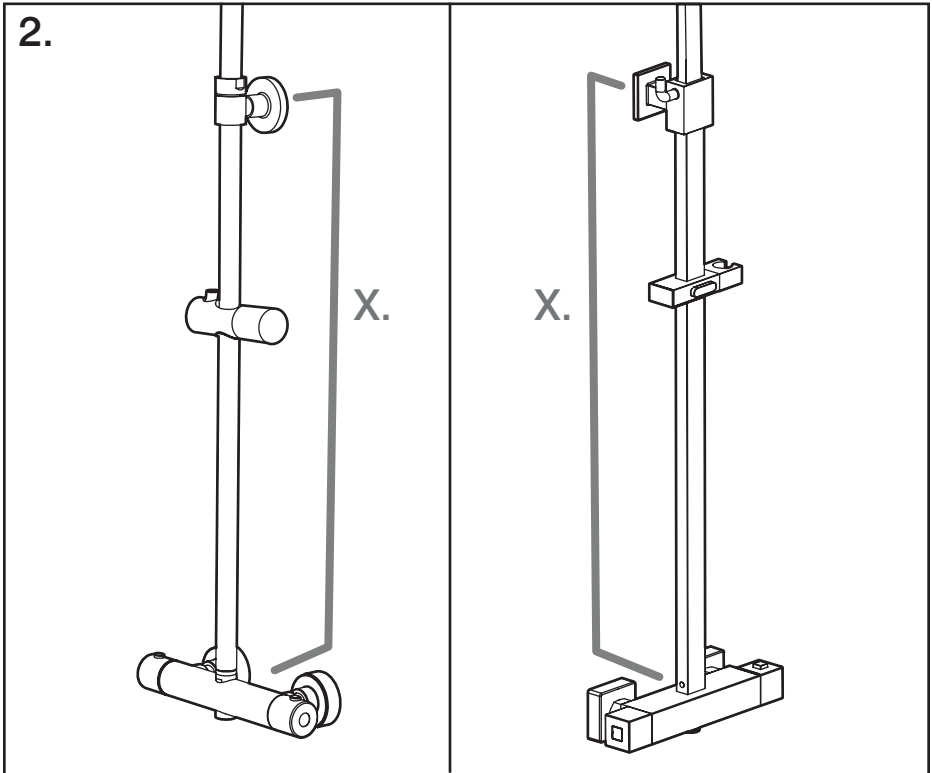

3. Secure the wall bracket in place using the fixings supplied.

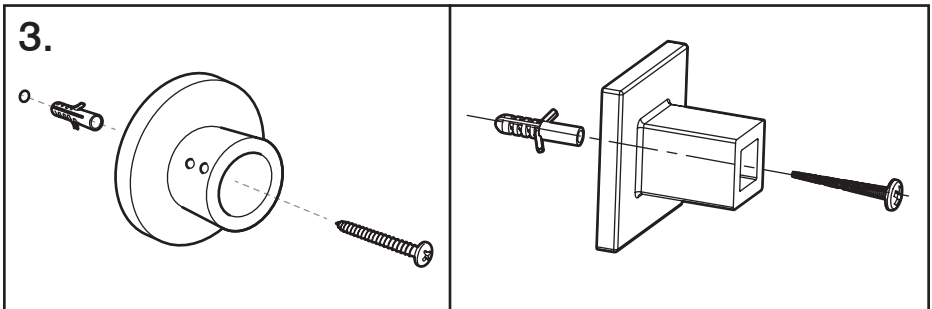

4. Offer up the riser rail to the wall bracket and secure in place using the grub screw on the wall bracket body.

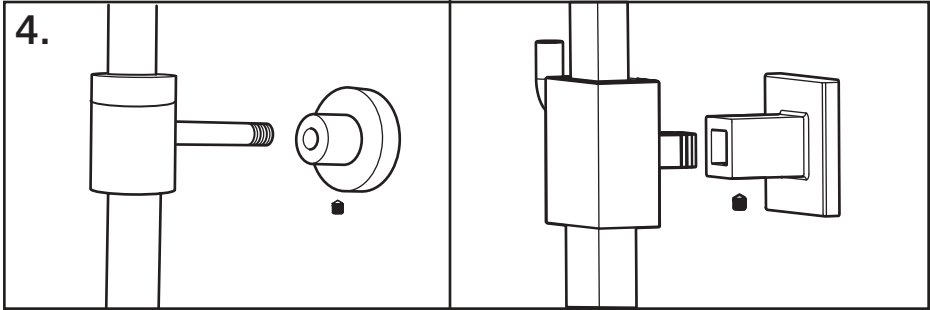

5. With the riser rail secured to the wall bracket, screw the shower head onto the 1/2" outlet. At this point the riser rail can be adjusted to the desired height.

For round systems, the riser rail fixing nut can be loosened and the rail can slide up or down to the chosen head position. Tightening the nut will fix the adjustable riser in place. For square systems there is a lever on the side of the riser rail that allows the rail height to be adjusted and then fixed in place.

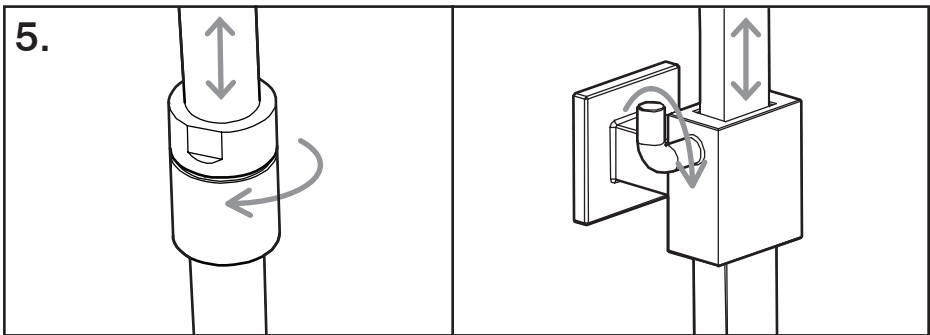

6. Assemble the shower hose to the threaded outlets on the bar valve body and the shower handset. Ensure that the rubber o-ring is positioned inside the hose swivel nuts to form a watertight seal at both ends.

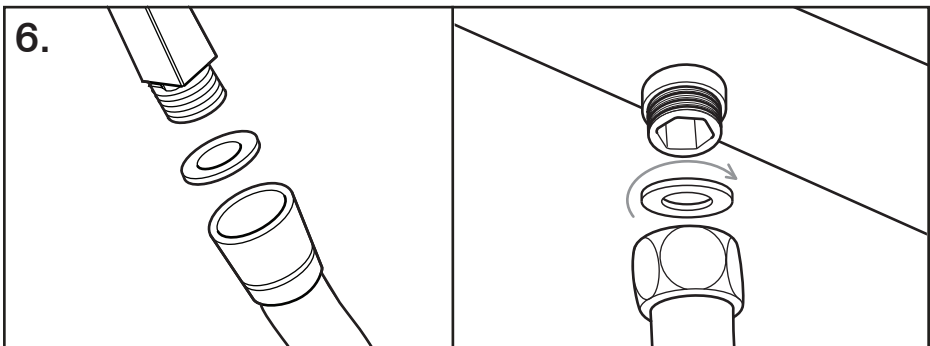

7. The riser rail kit is now fully installed and the shower system is ready for use. The rail and shower head height can still be adjusted after installation by following the method in step 4.

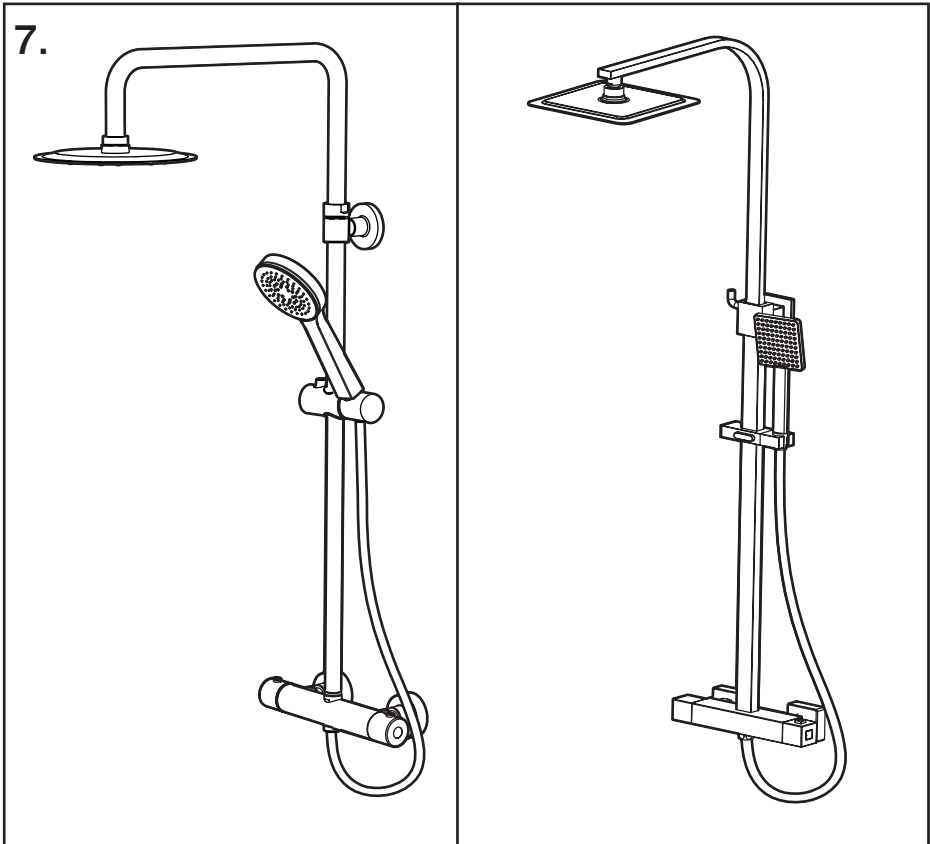

## CLEANING AND MAINTENANCE

Whilst all these items have a high quality durable finish, they should nevertheless be treated with care.

Surfaces should be cleaned using only a soft damp cloth and clean water then dried using a soft cotton cloth. Bath cleaning products, even non-scratch ones, could damage the finished surface.