

Press large button for long flush.

Press small button for short flush

General Care & Safety

Wall plugs supplied are ONLY suitable for solid stone/brick walls. They are not suitable for use in aerated blocks or similar. If fixing to a stud wall, sufficient extra internal reinforcements must be made to the wall. Screws must locate into suitably reinforced studs and noggins.

Take care using power tools – The use of a residual current device (RCD) is recommended. Beware of hidden cables or pipes when drilling.

This product can be dangerous if installed incorrectly. This product must be installed by a qualified plumber or installer. It is the installer's responsibility to check that the fixings are suitable for the installation in hand.

Cistern fittings are suitable for Water pressure: 0.1 - 10 bar. Do not add caustic chemical substances (e.g. containing chlorine compounds or similar) into the cistern. These can damage the valve components and cause failure.

Before starting to enclose the cistern, the system must be first tested for leaks before 2nd fix commences. Temporarily fix the back to wall pan in place and make connections. Turn the water supply on and flush the pan to check for leaks. This is particularly important to do prior to tiling for fully tiled in installations

This cistern is not suitable for use with wall hung pans without the use of a suitable supporting frame.



21

Personal Hygiene
BS EN 14055: 2010 - CL 2 - 6

Slimline Concealed Cistern

with Air Gap Technology

Please read completely first before commencing and retain for future reference

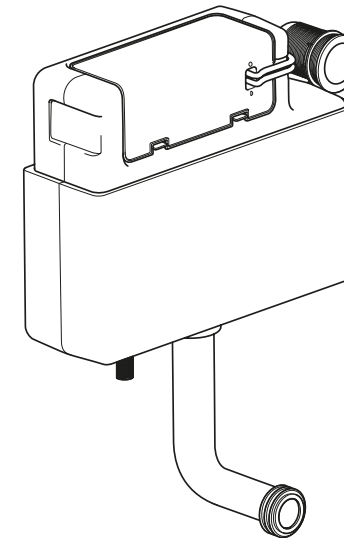

This product must be installed by a qualified fitter or plumber in accordance with and meet the requirements of Water Supply (Water Fittings) Regulations 1999, the Water Supply (Water Fittings) (Scotland) Byelaws 2014 and the Water Supply (Water Fittings) Regulations (Northern Ireland) 2009

Parts included

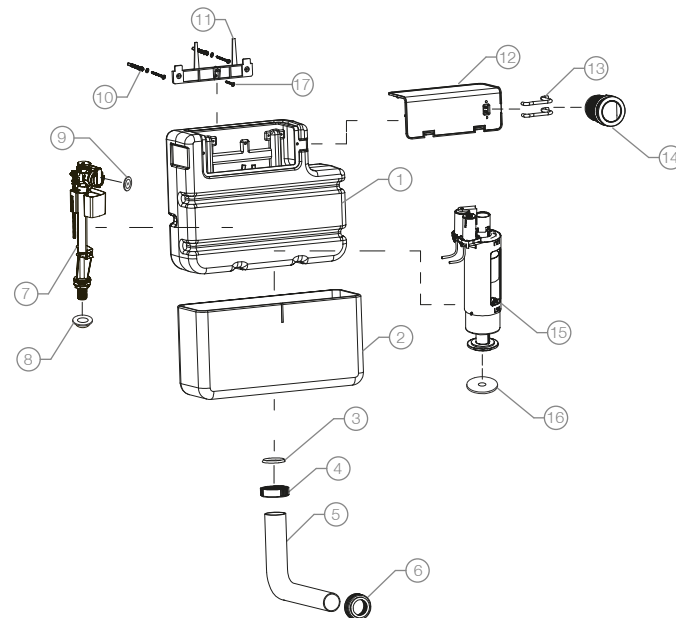

1. Cistern
2. EPS Jacket
3. Seal - SPI2168
4. Flush Bend Nut - SPI2168
5. Flush Bend - SPI2167
6. Pan Seal Cone - SPI2170
7. Bottom Entry Fill Valve - SPI9745
8. Stem Sealing Washer - SPI9757
9. Inlet Valve Diaphragm - SPI9756
10. 2 x Attaching Screws - SPI2163
11. Attachment Plate - SPI2163
12. Cistern Cover - SPI2164
13. Air Hoses - SPI7421
14. Pneumatic Push-button - SPI2169
15. Flush Valve - SPI2166
16. Flush Valve Flapper Seal - SPI2551
17. Cistern Fixing Screw - SPI2163

Fitting dimensions

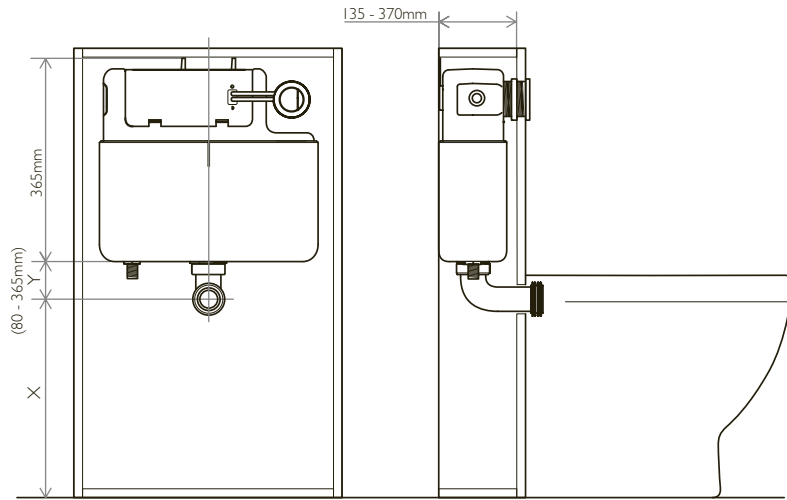

Installation of the cistern

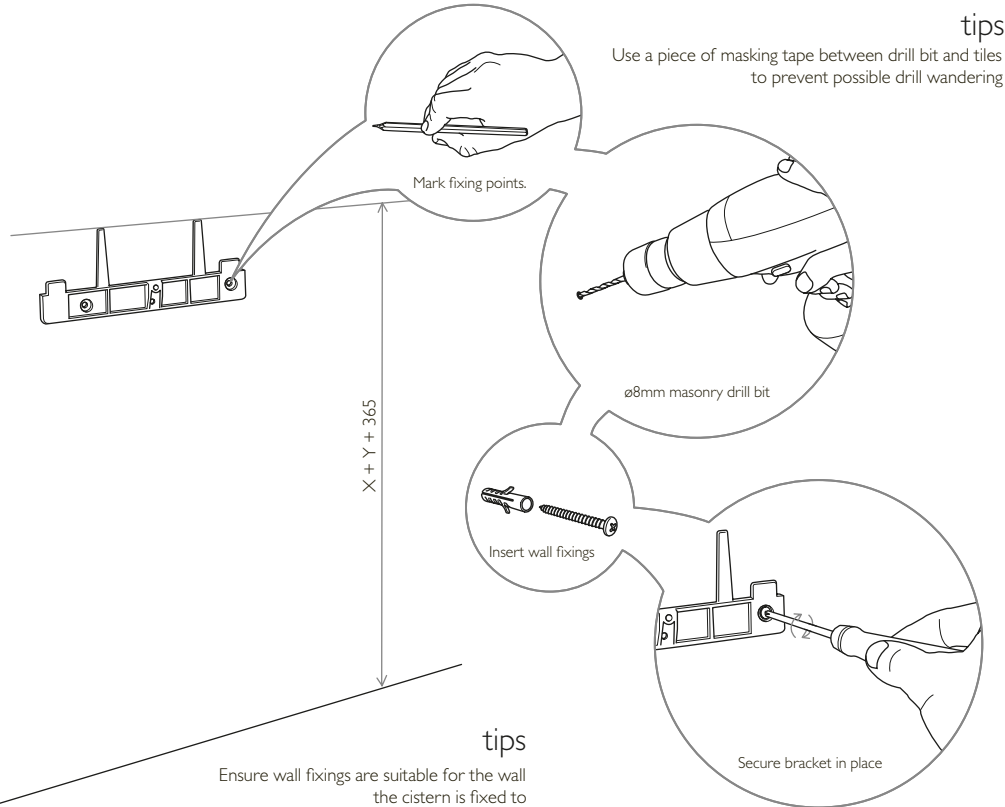

Inlet Valve Adjustments and Maintenance

By adjusting the fill valve the water level can either be increased or decreased accordingly

Flush Volume (Full/Reduced)	Nominal Water Level
6L/3L	198mm

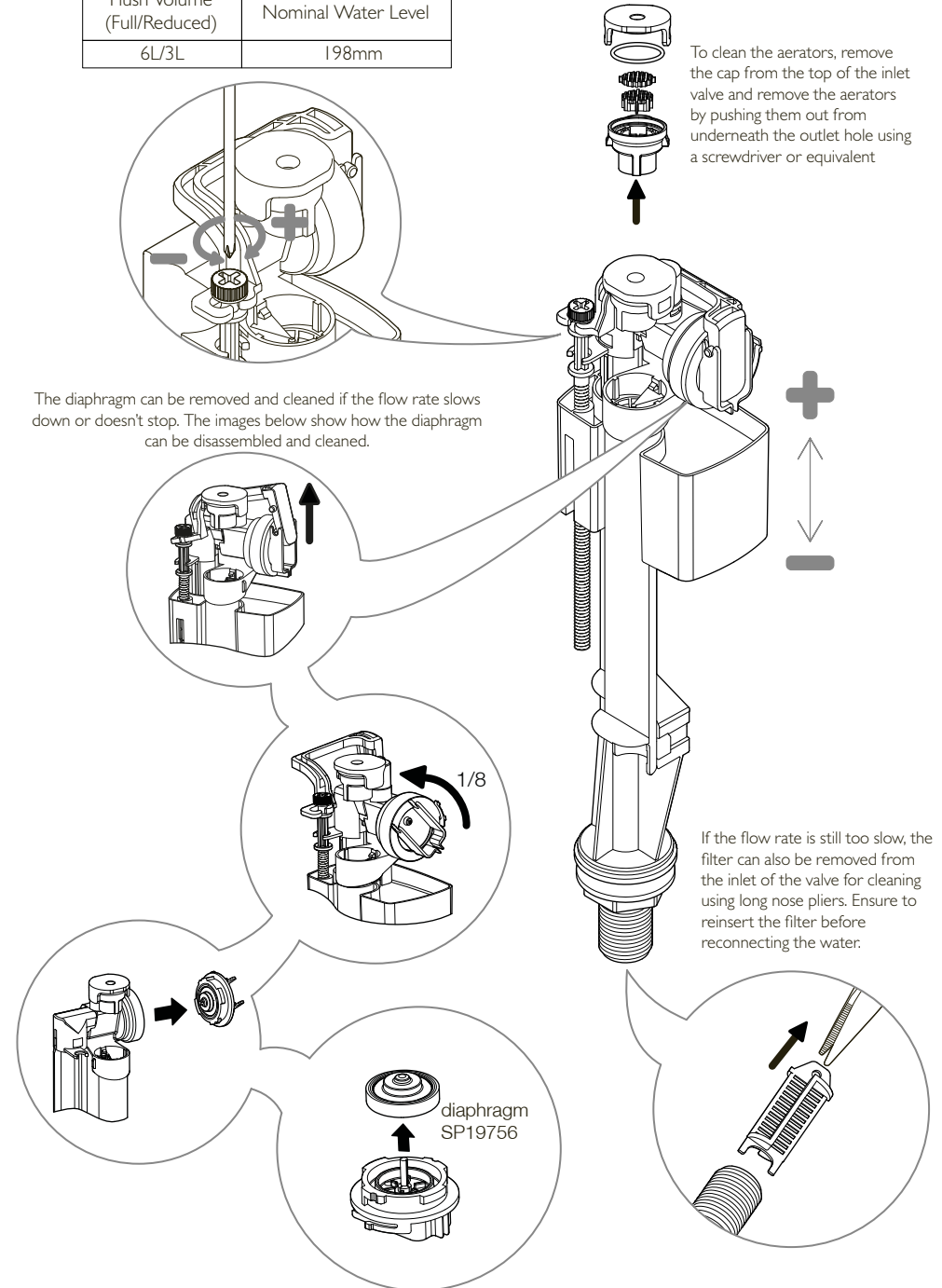

Fixing the toilet

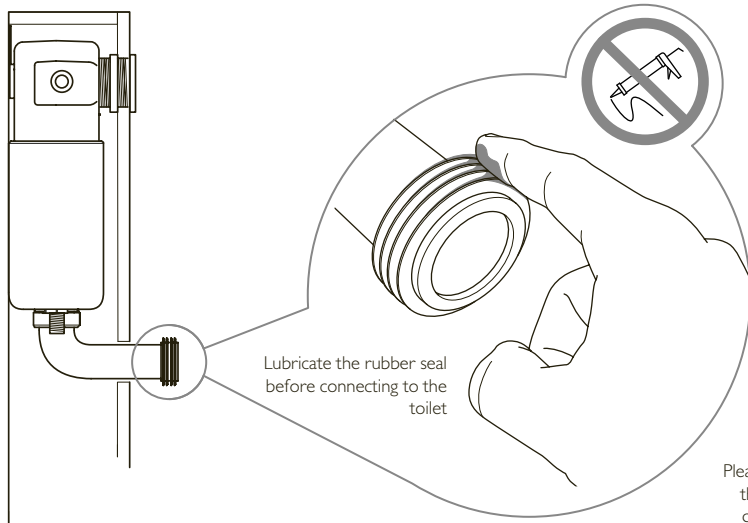

Lubricate the rubber seal before connecting to the toilet

note
Lubricant not supplied, please use a suitable plumber's grease. Silicone **MUST NOT** be used as this may prevent a seal being formed.

important
Great care must be taken when fixing the toilet. Careful cutting of the pipe and alignment are very important to ensure no leaks occur.

important
Please support the flush pipe when locating the toilet onto the rubber seal. Failure to do so could result in damage to the flush connection

Adjusting the flush volume

By adjusting the settings on the flush valve, the flushing volume can be altered

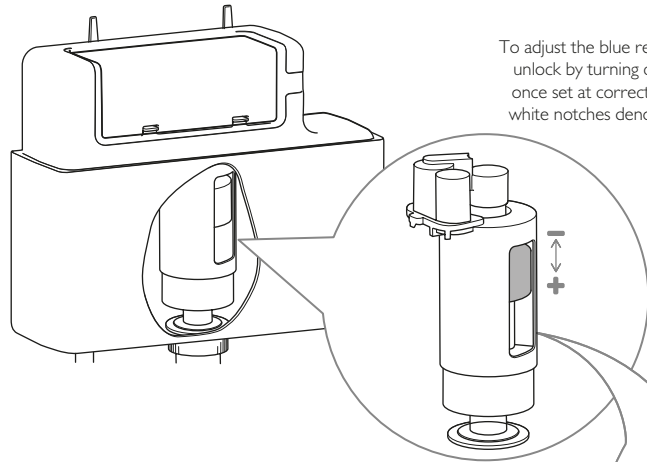

To adjust the blue reduced flush slider unlock by turning clockwise and lock once set at correct level. Each of the white notches denotes 1 level on the settings.

To adjust the white flush tab, hold the flush valve open and slide the tab into the desired position, using the scale behind to determine the setting.

flush valve settings

Flush Volume (Full/Reduced)	Full Setting	Reduced Setting
6L/3L	6	8

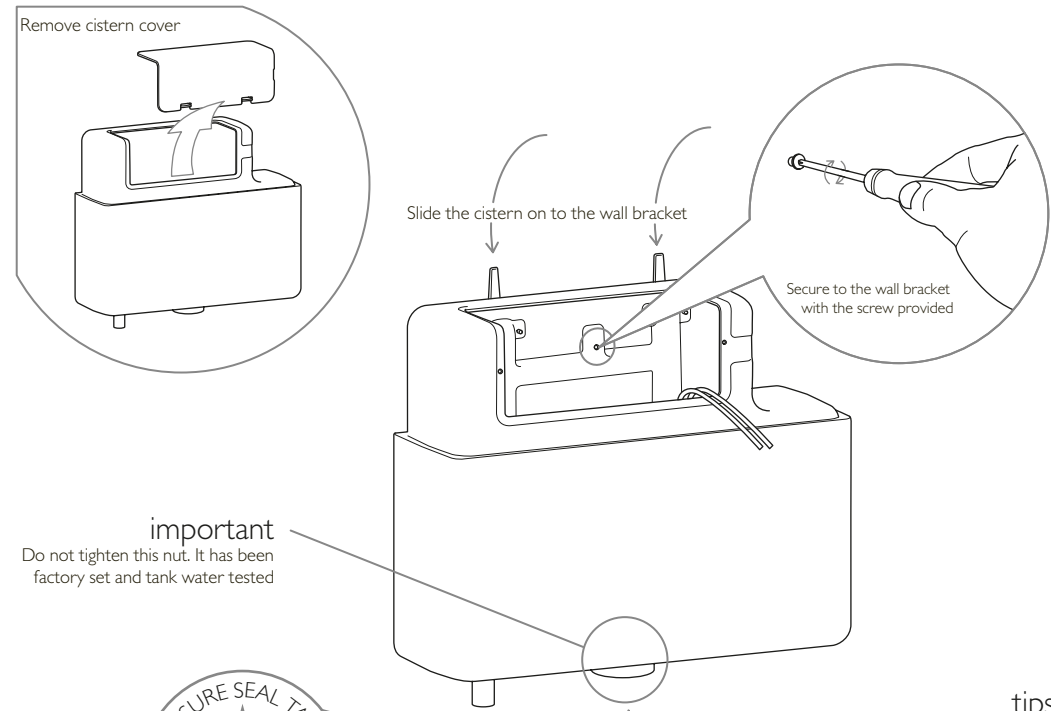
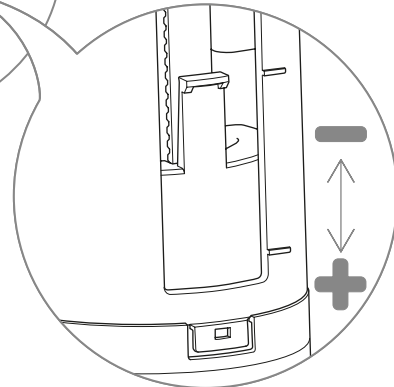

important
Do not tighten this nut. It has been factory set and tank water tested

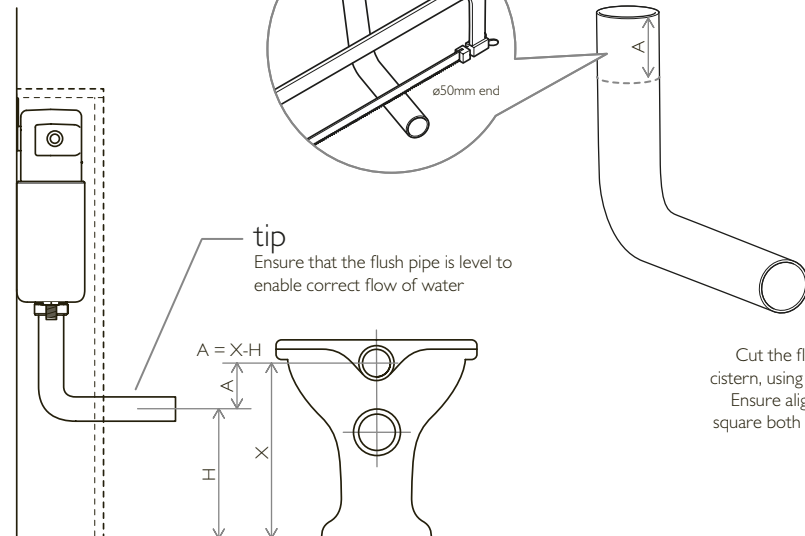
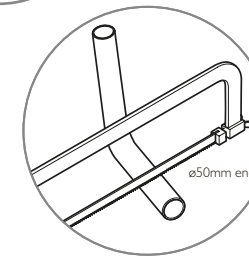

tip
Ensure that the flush pipe is level to enable correct flow of water

tips

It is recommended that the flush bend be adequately braced against the wall using an appropriate pipe bracket or wooden packing. Ensure there is no tension / stress on the connection to the tank as this could cause the fittings to leak.

Cut the flush bend to size and attach to the cistern, using the appropriate fittings, as shown. Ensure alignment to pan from cistern tank is square both vertically and horizontally to allow seal to function correctly

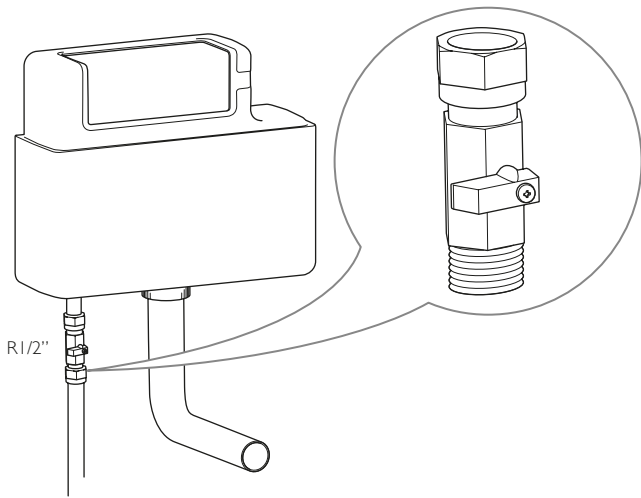

note
Check valve not included

Connect the water supply to the cistern using an approved double check valve to fluid category 3 in addition to an accessible service or isolation valve.

important
This product is to be installed in a concealed location only.

Installation with a front access panel

important

- full flush = clear hose
- ⓓ reduced flush = blue hose

Unobstructed access opening size minimum 500mm x 130mm

min 130mm

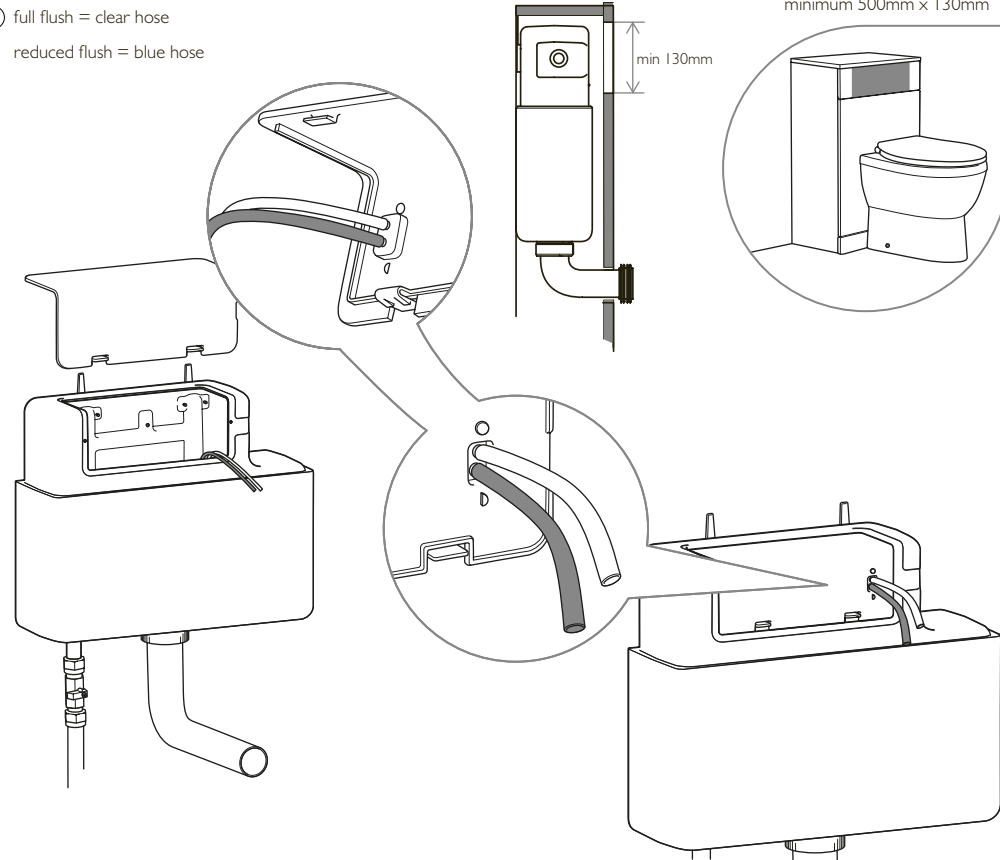

Installation with a top access panel

max 25mm
min 110mm
Unobstructed access opening size minimum 500mm x 110mm

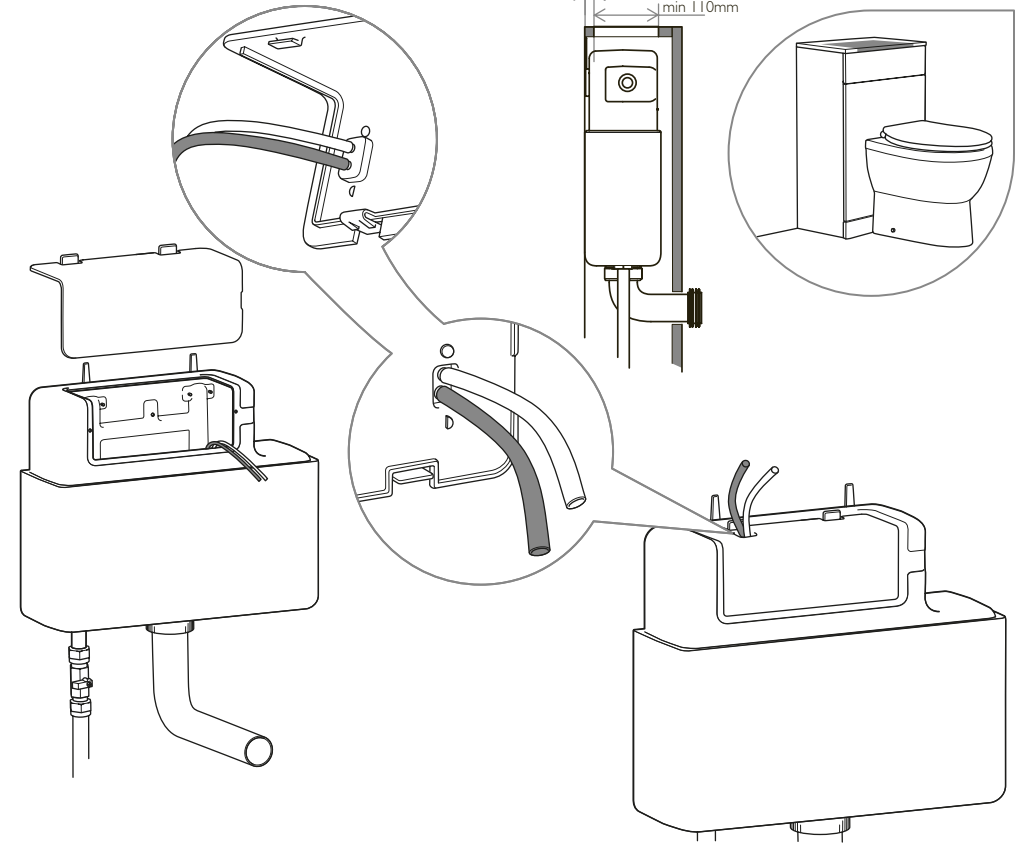

Installation of pneumatic push-button

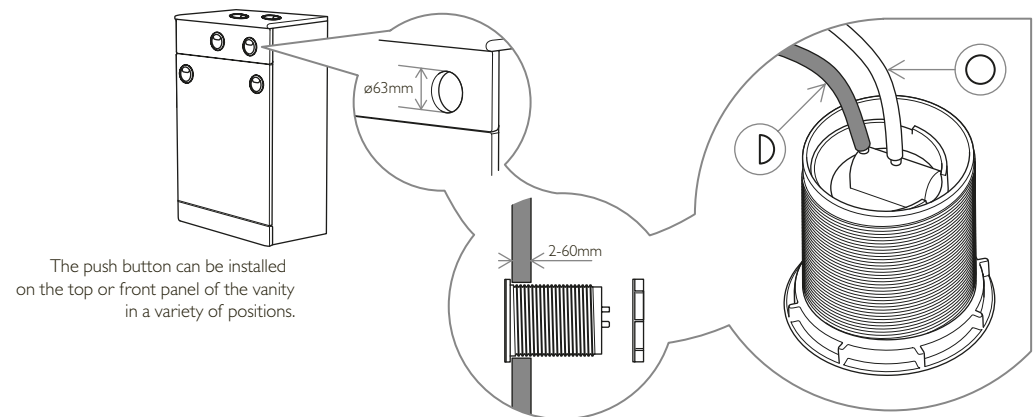

The push button can be installed on the top or front panel of the vanity in a variety of positions.

Troubleshooting Guide

Concealed Cistern

Please retain for future reference

How to Access your cistern

1. Remove fascia panel
2. Remove the blue cover on the cistern

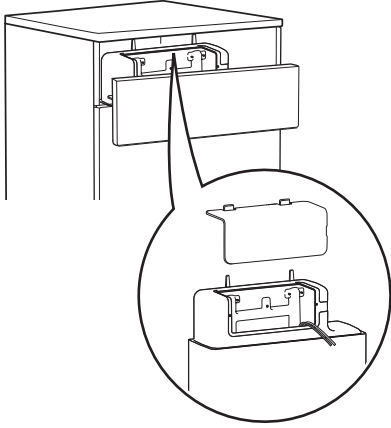

1. Shut off Water Supply
2. Unscrew the nut from the flexible hose
3. Pull out the fill valve

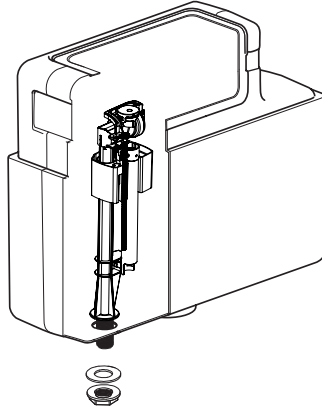

1. Gently twist & remove flush valve (anti-clockwise)

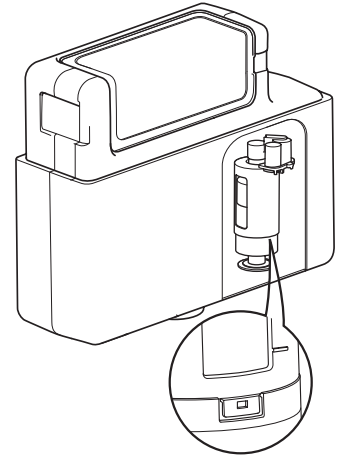

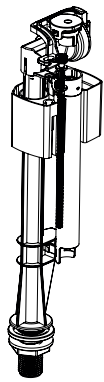
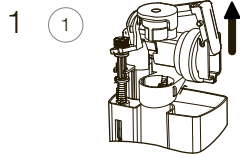
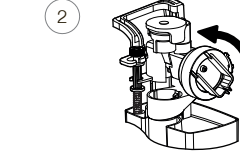
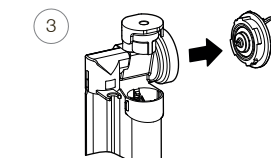
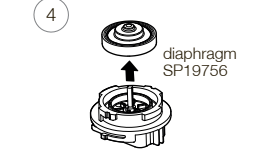
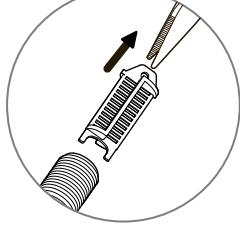
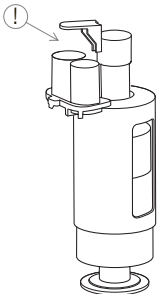
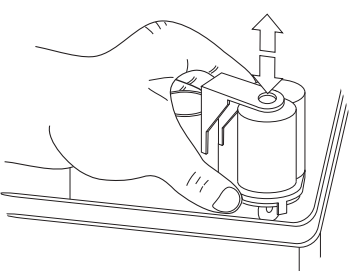
Problem	Potential cause	Suggested action
<p>The Fill Valve does not work or isn't controlling the water supply efficiently.</p>	<p>The inlet valve may be blocked.</p> 	<p>Follow the instructions below and clean the water inlet orifice, diaphragm and cap. If split or scaled up, replace the diaphragm, available as SP19756.</p>      <p>To clean the aerators, remove the cap from the top of the inlet valve and remove the aerators by pushing them out from underneath the outlet hole using a screwdriver or equivalent</p> <p>If the flow rate is still too slow, the filter can also be removed from the inlet of the valve for cleaning using long nose pliers. Ensure to reinsert the filter before reconnecting the water.</p>
<p>Water leaks from the base.</p>	<p>1 The flush valve stem may be obstructed or jammed, preventing it from falling back into position.</p> 	<p>Ensure that there is nothing obstructing the flush valve and the stem can extend up and down.</p> 

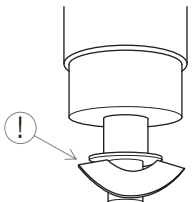
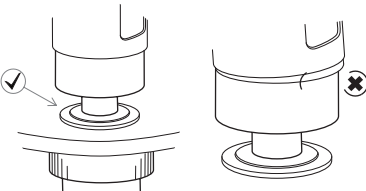
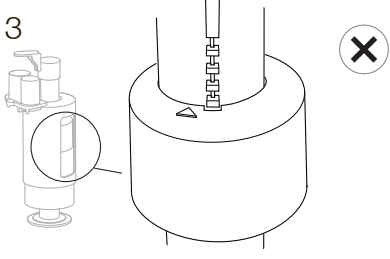
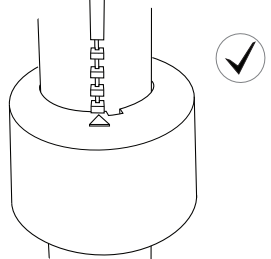
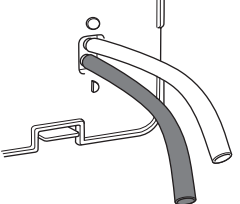
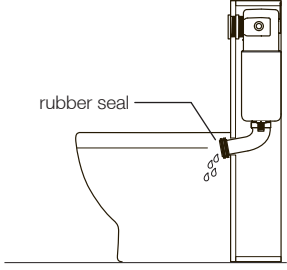
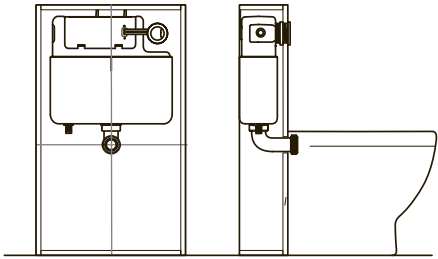
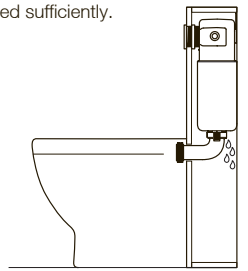
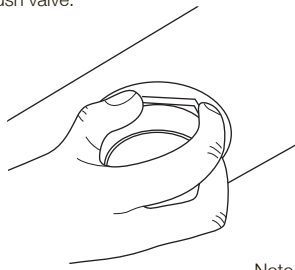
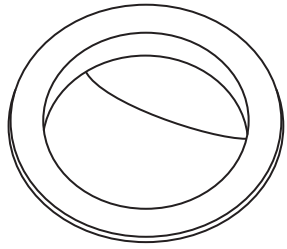
Problem	Potential cause	Suggested action
<p>Water leaks from the base. (Continued)</p>	<p>2 The rubber flapper seal may have fallen off, may need cleaning or could be damaged.</p> 	<p>Ensure the flapper seal is fixed in position. However, if it's damaged a replacement is needed, this is available as SP12551.</p>  <div data-bbox="1308 190 1540 369" style="border: 1px solid black; padding: 5px;"> <p>NOTE: Before re-fitting the flush valve assembly check the base is correctly seated as shown to the left and not out of position (see below as an example)</p> </div>
	<p>3</p> 	<p>Ensure the rotation of the blue, reduced flush float is in the correct position, and has locked in place securely.</p> <p>If it isn't (as shown left) the float can catch on the adjustment measure. To lock in place, simply rotate the float anticlockwise.</p> 
<p>The flush valve does not work properly.</p>	<p>The pneumatic tubes may be pinched or may have been installed incorrectly.</p>	<p>The blue tube must be connected to the joint marked with a half circle,</p> <p>The transparent tube should be connected with the joint marked with a full circle.</p> <p>Ensure the same configuration is used on the flush button</p> 
<p>The pan washer is leaking.</p>	<p>The cistern may have been installed in an incorrect position causing the flush bend to pull out of position, or silicone has been used around the rubber seal.</p> 	<p>Ensure the cistern is in the correct position and ensure the flush bend is fully connected to the pan. NEVER use silicone on the rubber seal as this will impair the ribs and prevent a proper seal being formed.</p> <p>Please see the instruction manual provided for fitting instructions.</p> 
<p>Water leaks between the cistern and base</p>	<p>The nut connecting the flush bend with the cistern body may not be tightened sufficiently.</p> 	<p>Ensure the nut is fully tightened by hand and the flush pipe is vertically installed into the flush valve.</p>  <p>Note - do not over-tighten</p>
<p>The pneumatic push button doesn't reposition itself once pressed downwards</p>	<p>It may be a fault with the air compression or the button itself could be broken</p> 	<p>Check the pneumatic tubes are connected properly. If the button is faulty then it will have to be replaced with another one, available as SP12169.</p> 